

EINHEITSDIESEL

Fernsprechbetriebskraftwagen (heavy telephone exchange van)









Cat. no. 35004







Scale 1/35



Project, design & artwork: Jarosław Leoniec
Research: IBG crew

Special thanks for his priceless help
for Mr. Henryk Herzik

-  Element złożony we wcześniejszym etapie
Element assembled in previous step
-  Element po złożeniu w aktualnym etapie
Element after assembly in actual step
-  Wersja do wyboru
Version to choose
-  Kalkomania
Decal
-  Kolor farby
Paint colour
-  Część nie do użycia
Part not for use

		Gunze Mr.Color	Model Master Acrylic	Humbrol	Valleyo MC
black		C002	4695	21	861
wood		C043	4673	110	846
gunmetal		C104	4681	53	863
panzer gray		C040	4795	67	995
rust		C029	4675	113	846
leather		C019	4674	62	843

Przed montażem przeczytać instrukcję. Przestrzegać kolejności montażu podanego w instrukcji! Klej i farby nie wchodzi w skład zestawu.

Please read instruction before assembly. Obey sequence of assembly like in instruction. Glue and paints not included.

Ramka przezroczysta / Frame clear

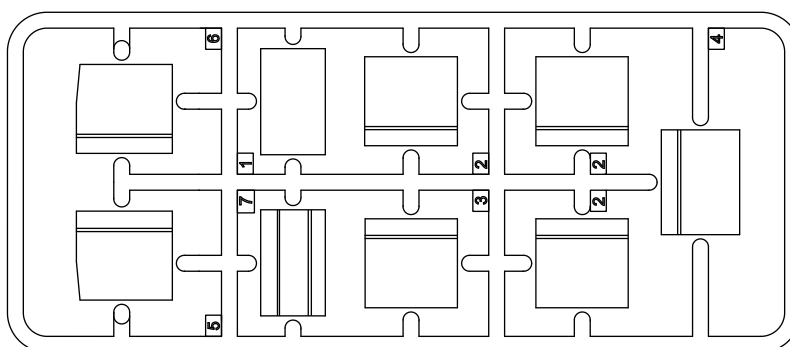

International Business Group
ul. Benedykta Hertzka 2
04-603 Warszawa
Poland

tel +48 22 8159150
fax +48 22 8159151
ibgsc@ibg.com.pl
www.ibg.com.pl

Ramka X / Frame X

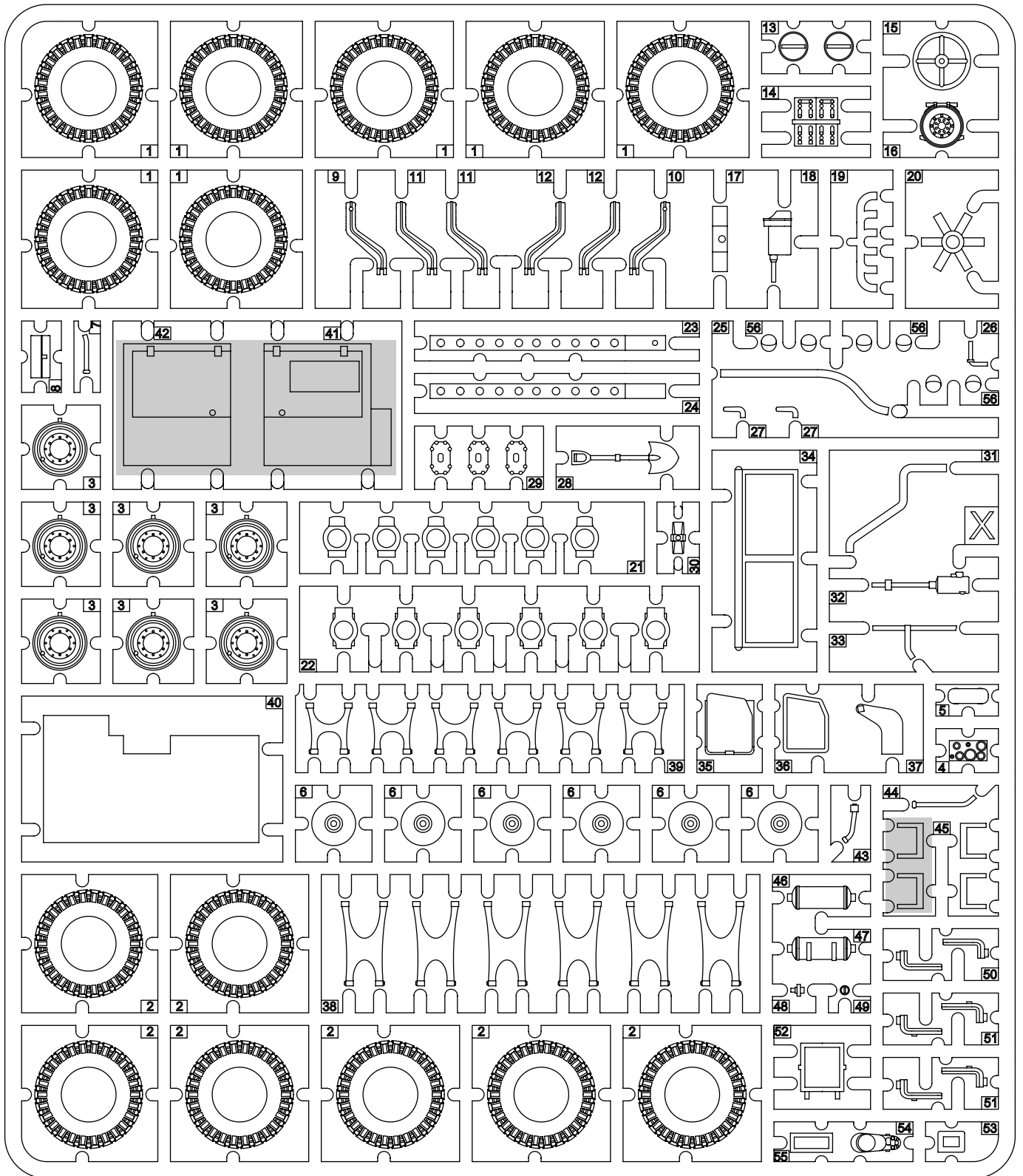

Ramka Y / Frame Y

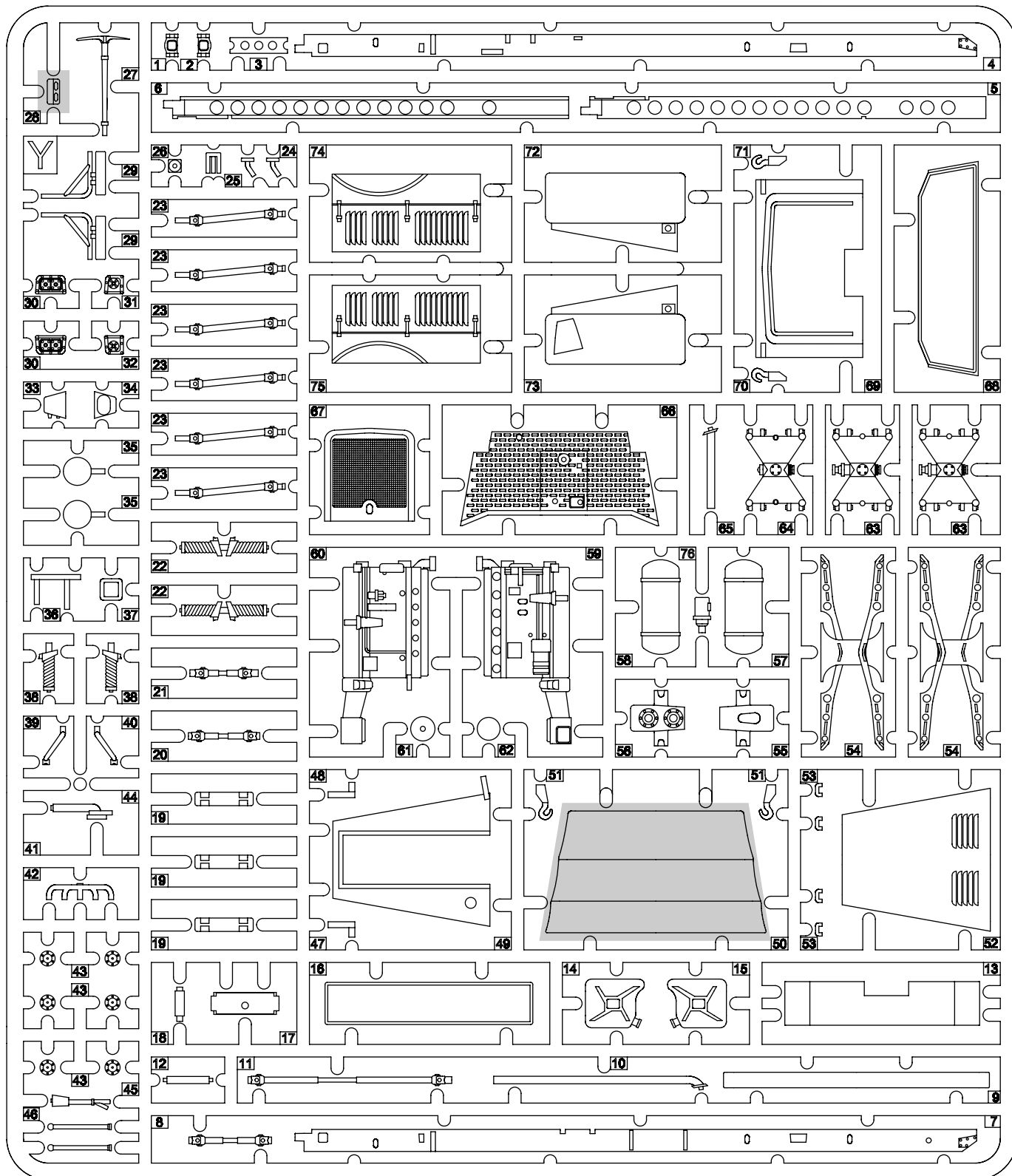

Ramka B / Frame B

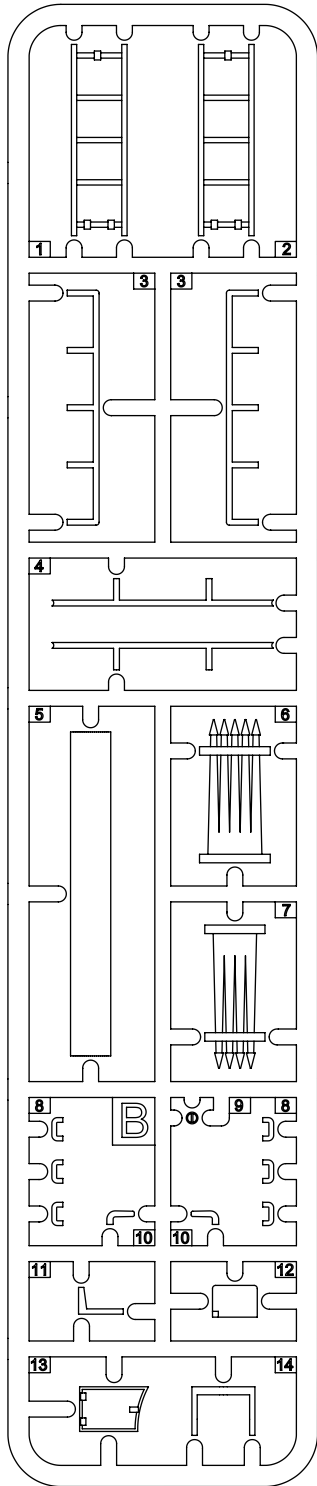

Ramka A / Frame A

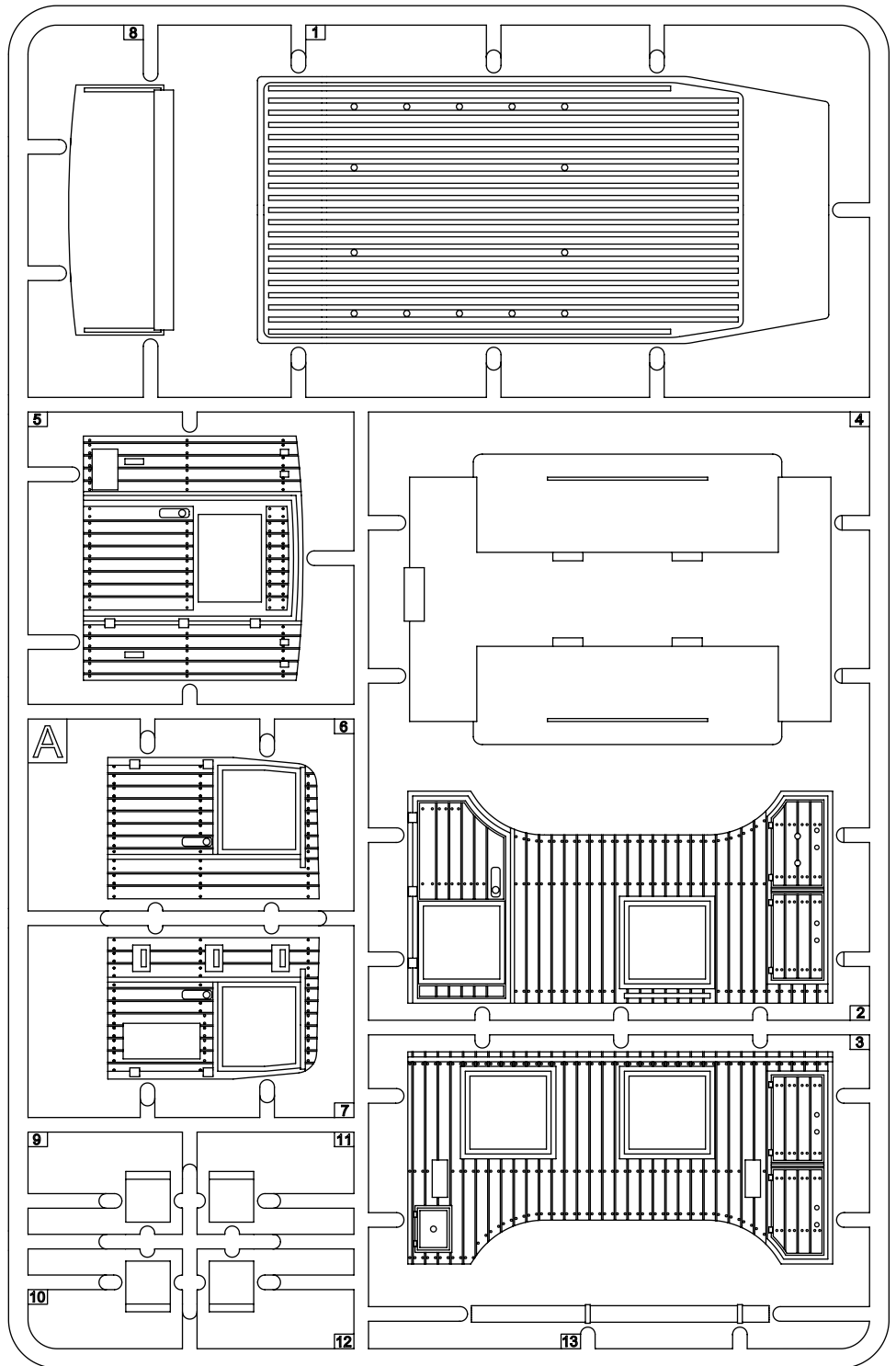

**ETAP 1
STEP 1**

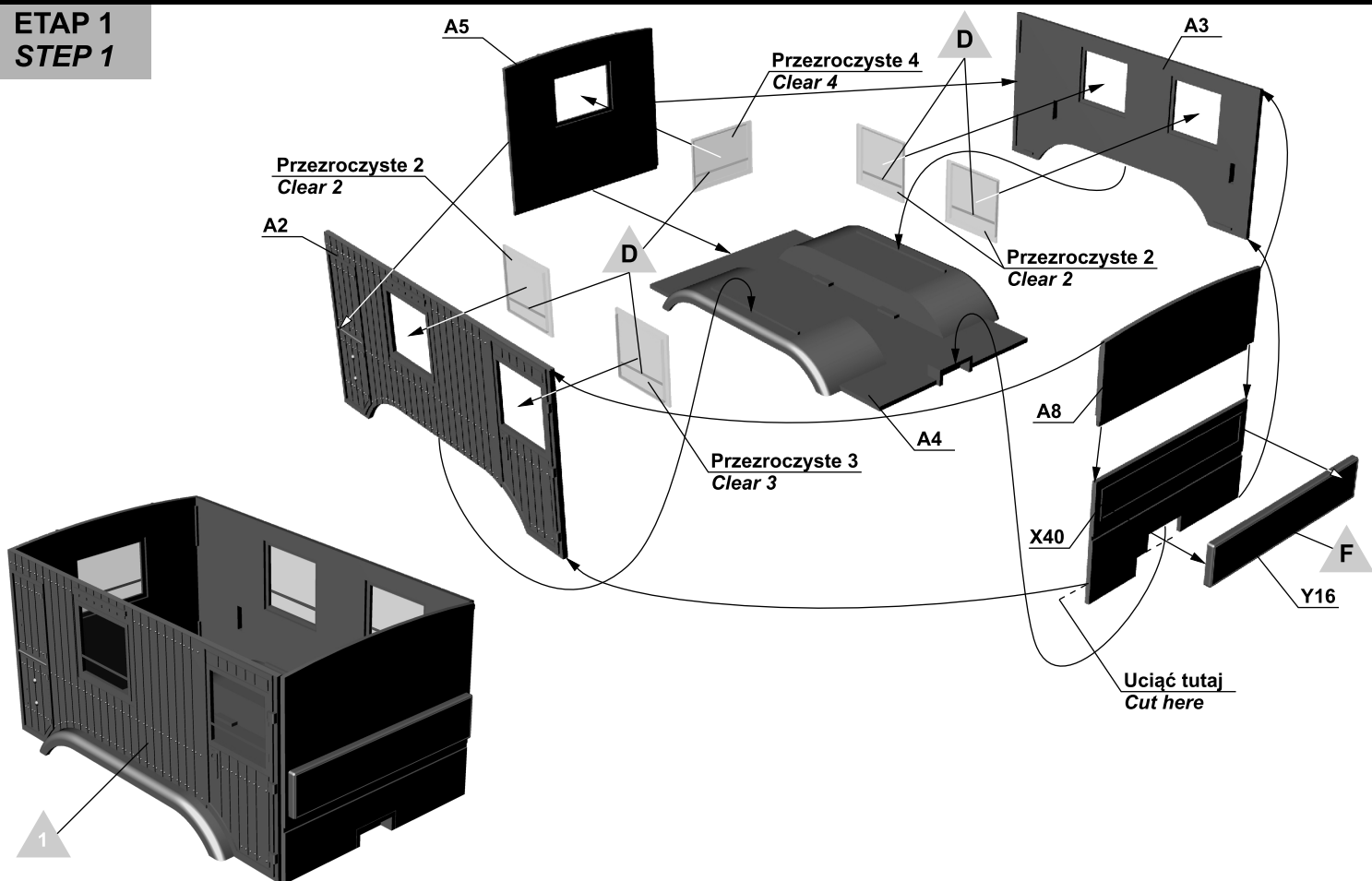

**ETAP 2
STEP 2**

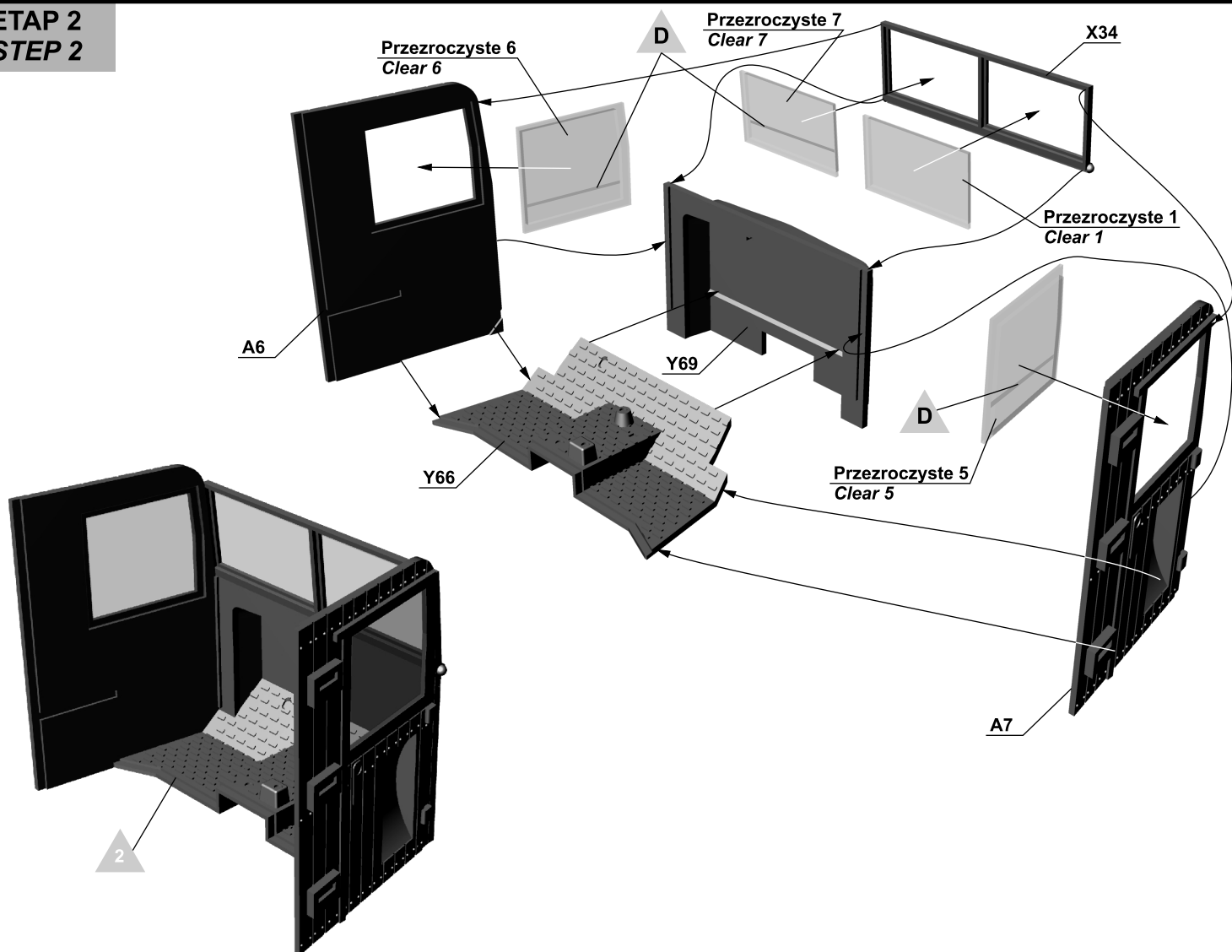

ETAP 3
STEP 3

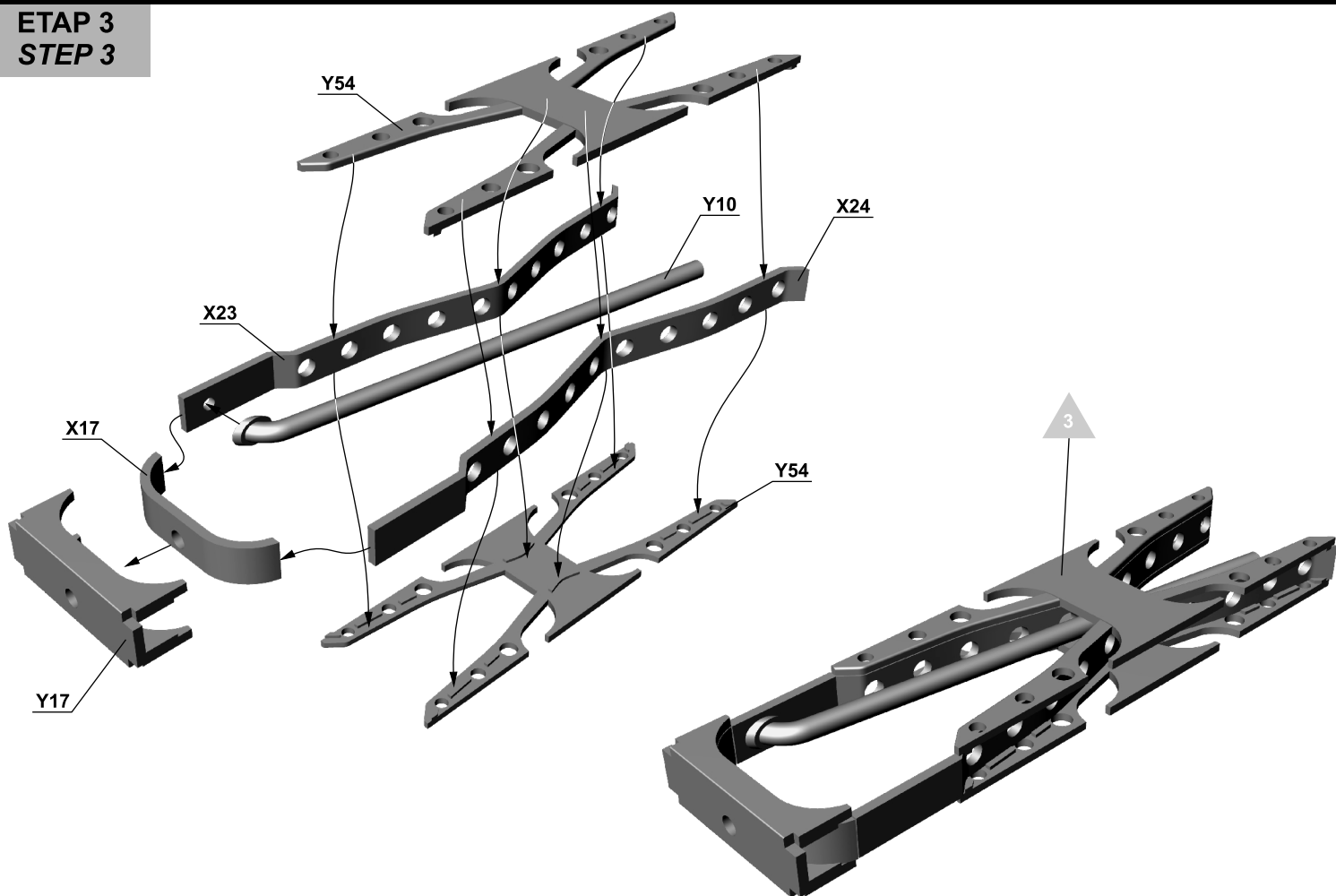

ETAP 4
STEP 4

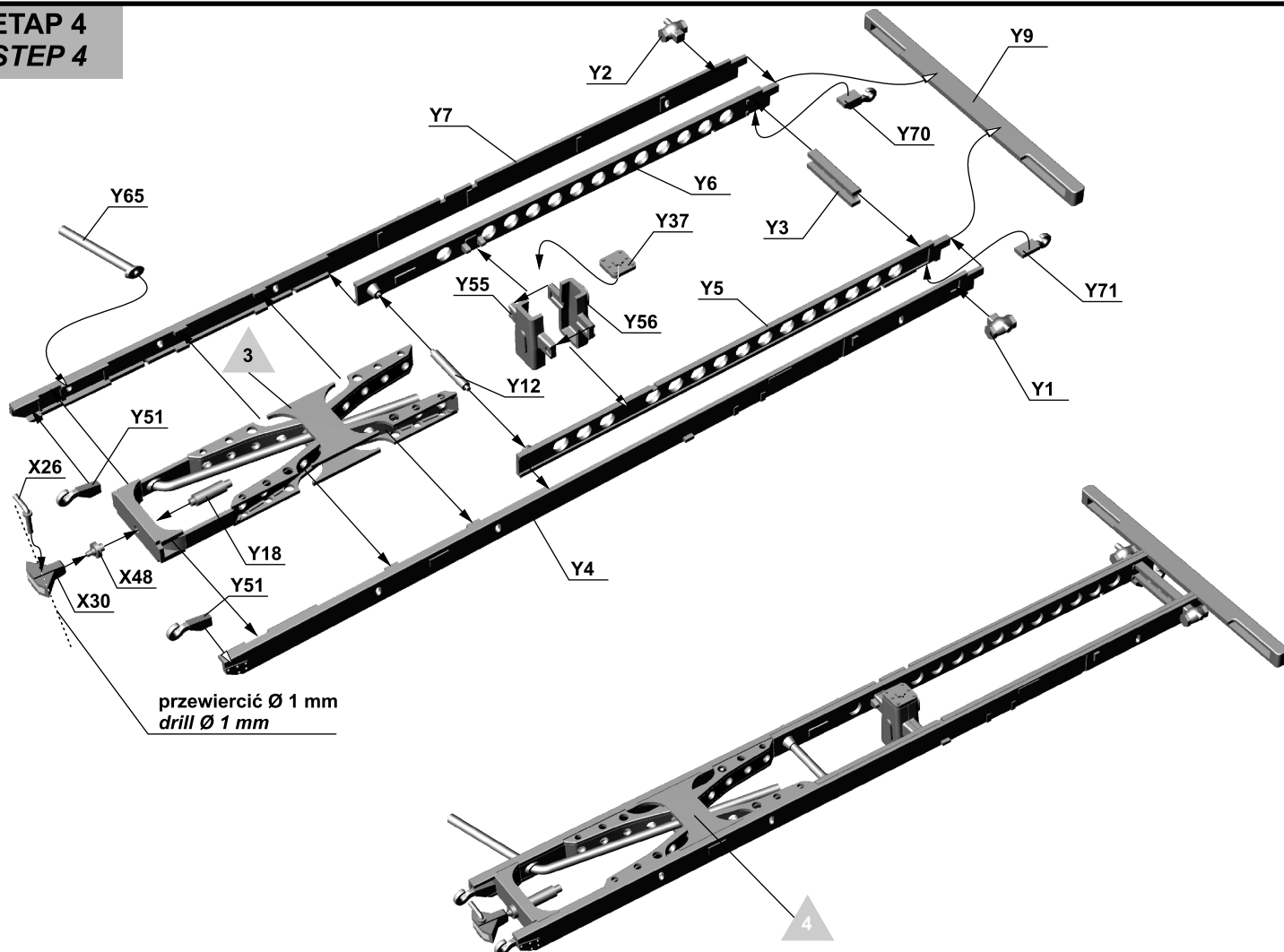

**ETAP 5
STEP 5**

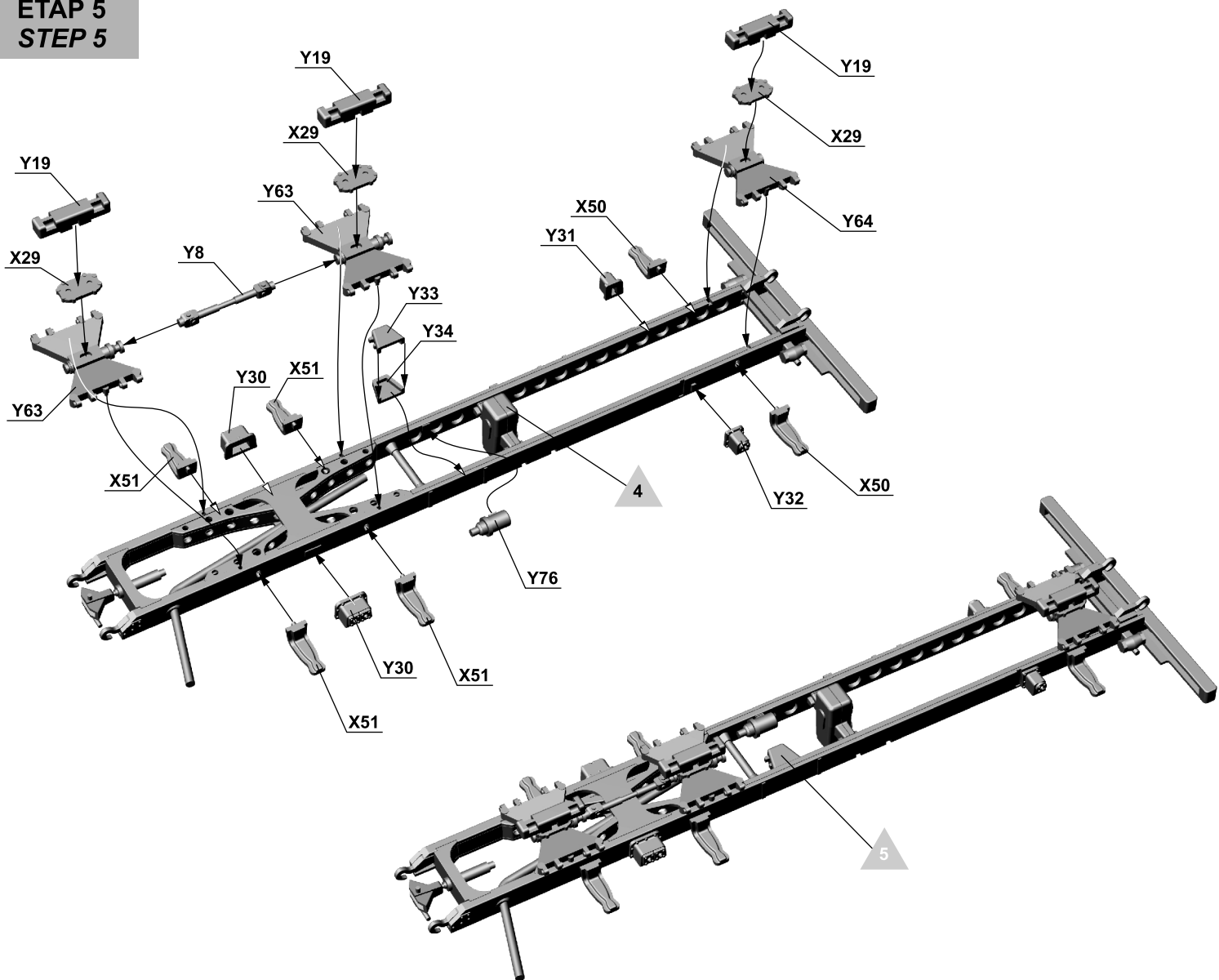

**ETAP 6
STEP 6**

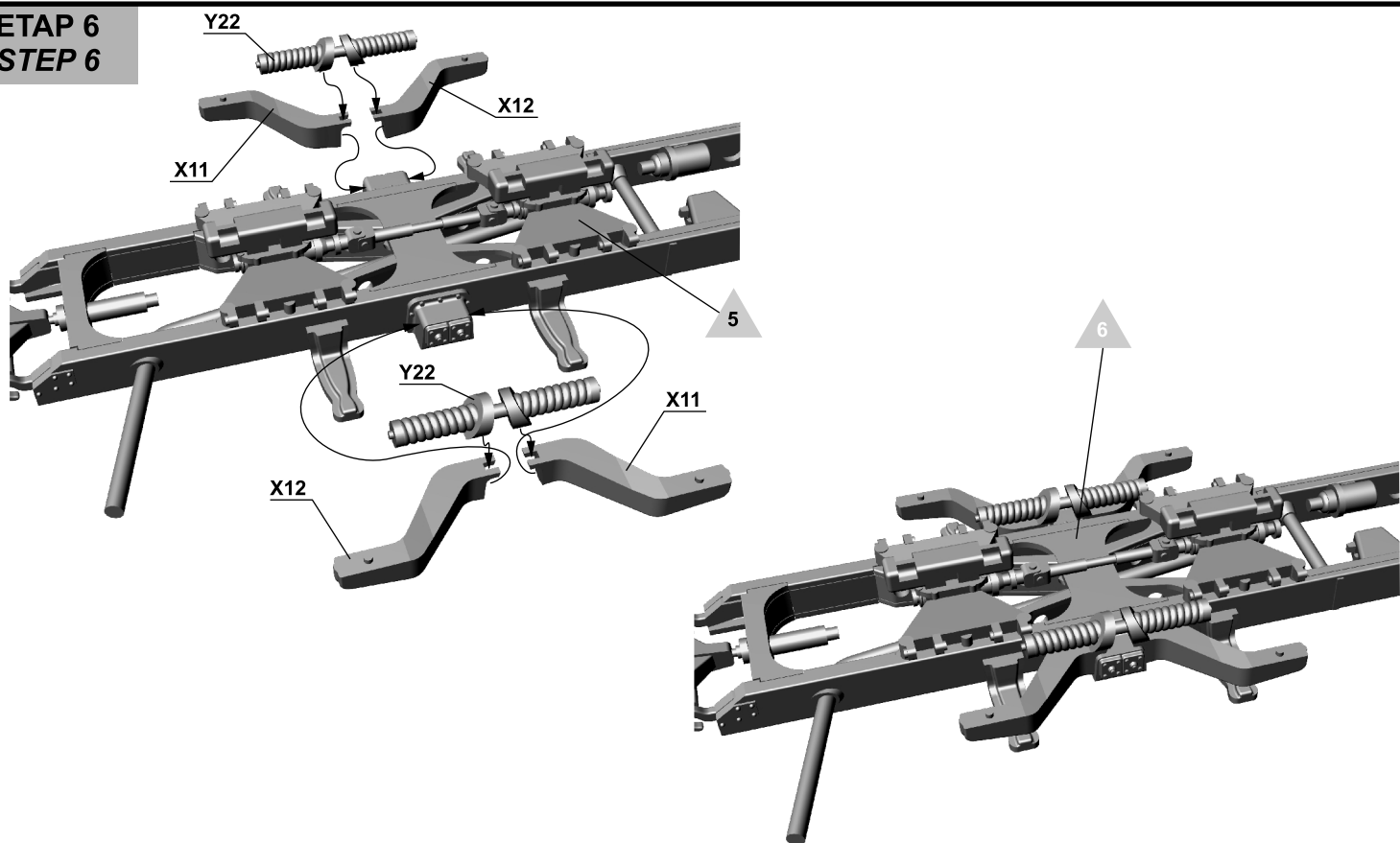

ETAP 7
STEP 7 x 7

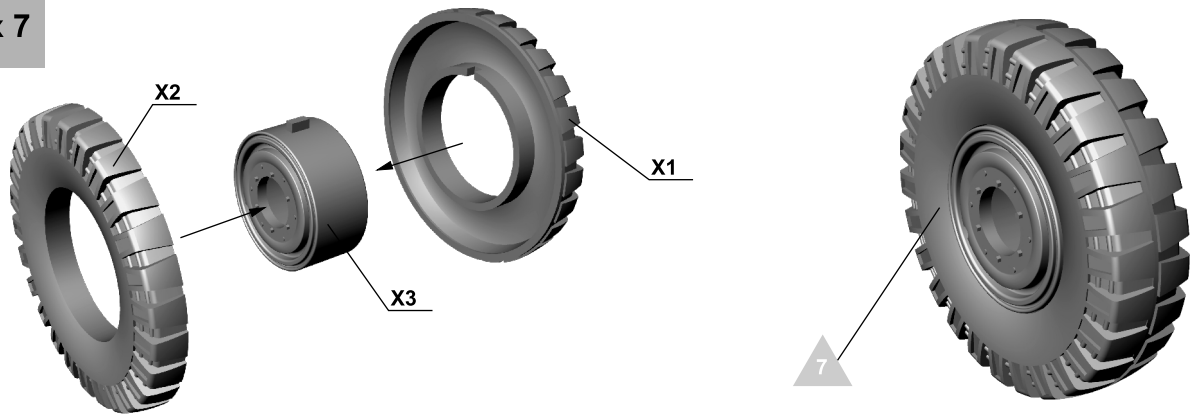

ETAP 8
STEP 8

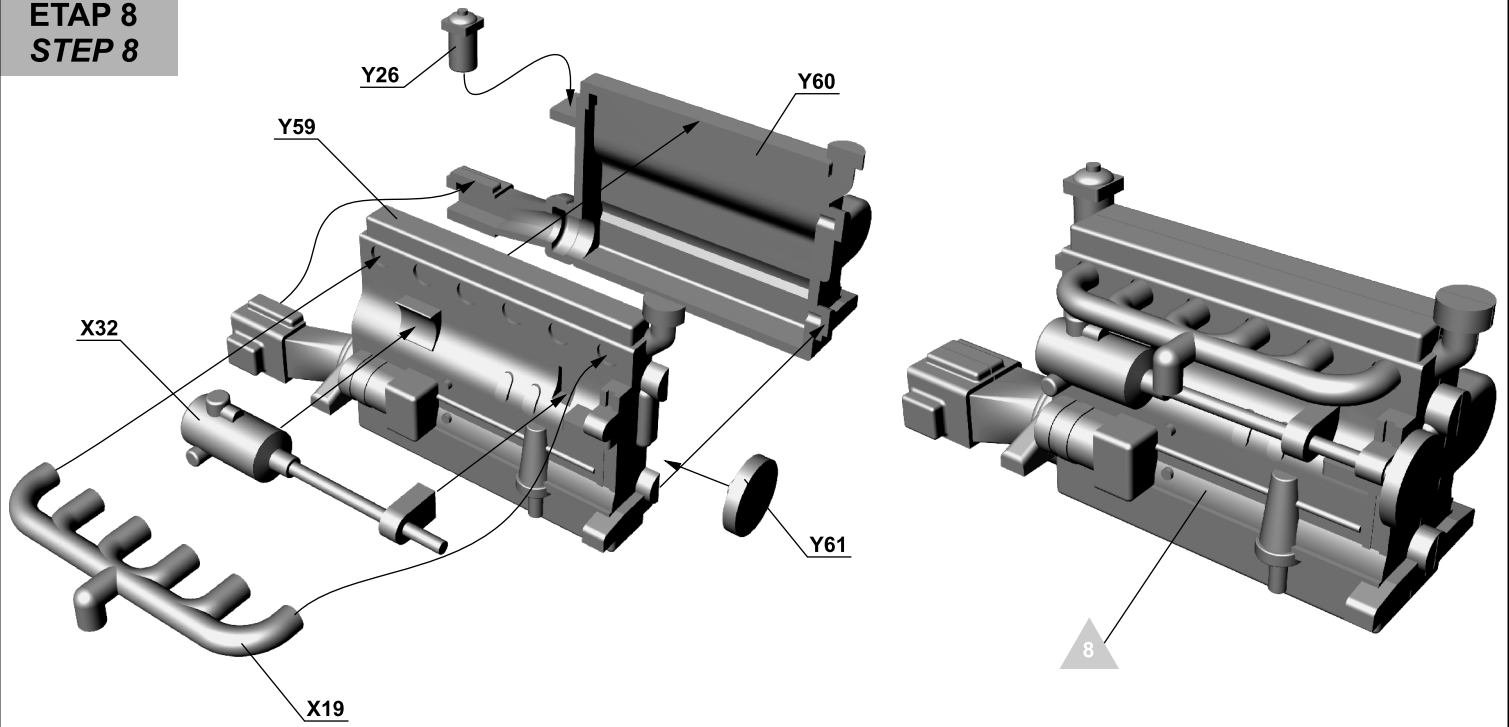

ETAP 9
STEP 9

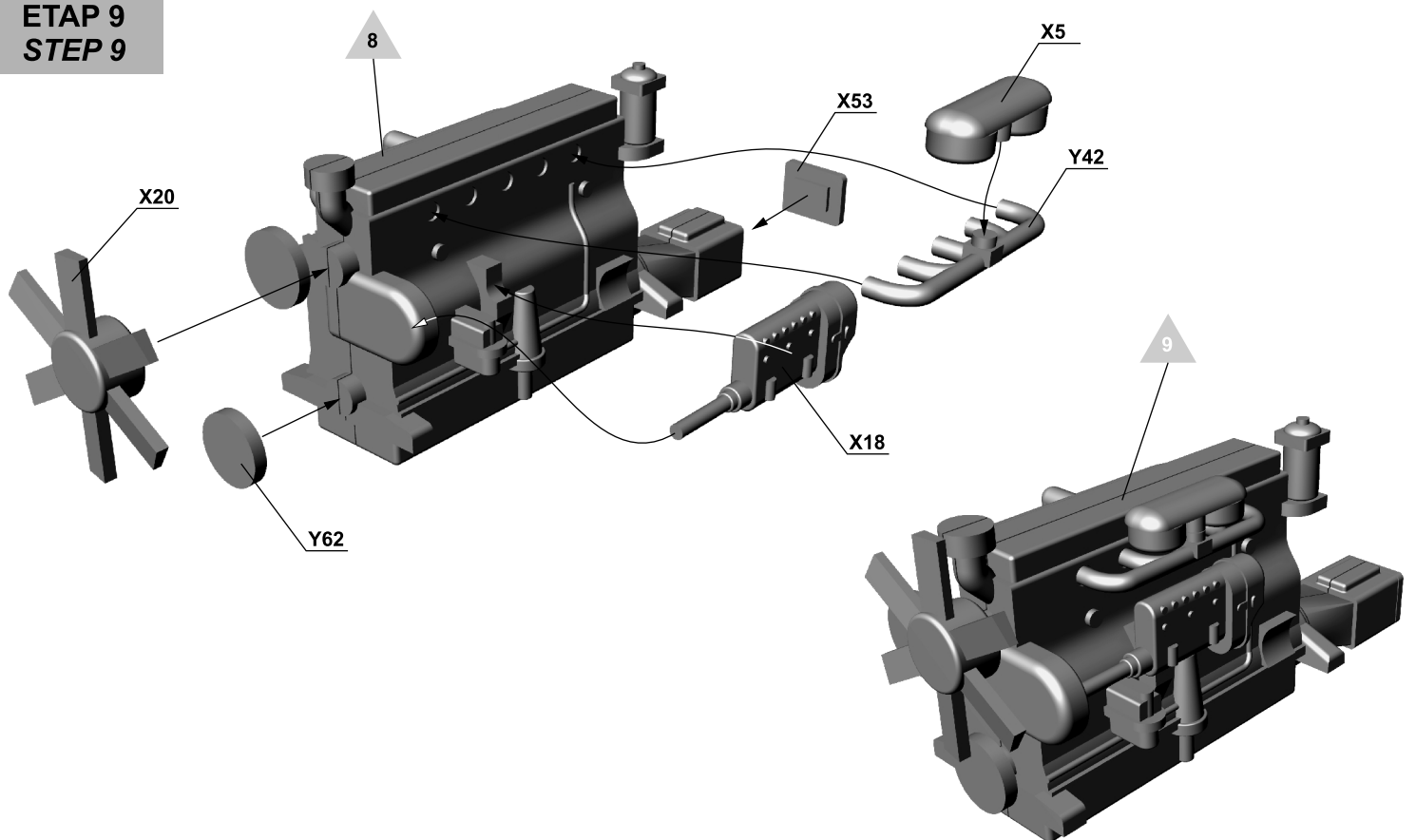

ETAP 10
STEP 10

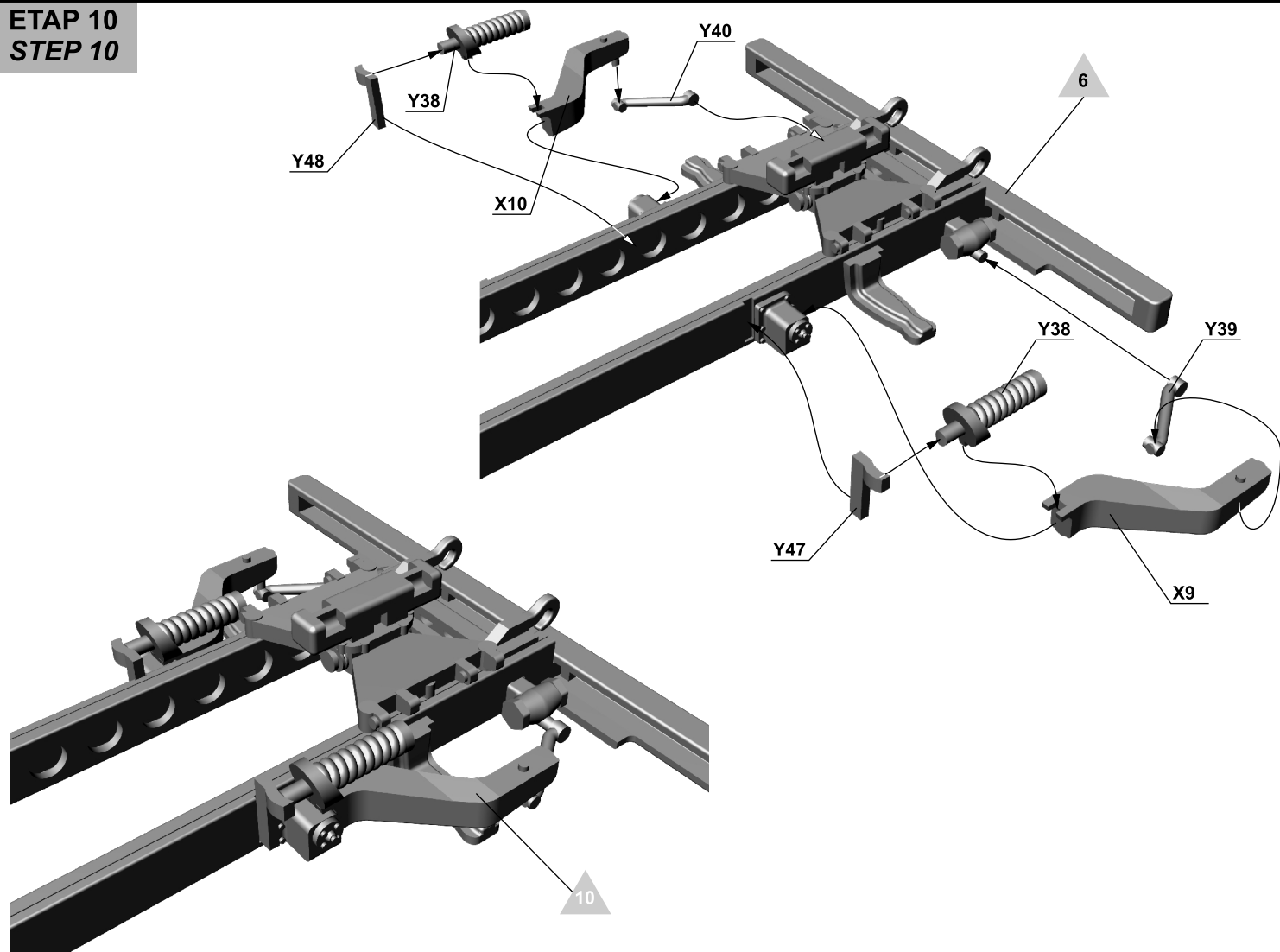

ETAP 11
STEP 11

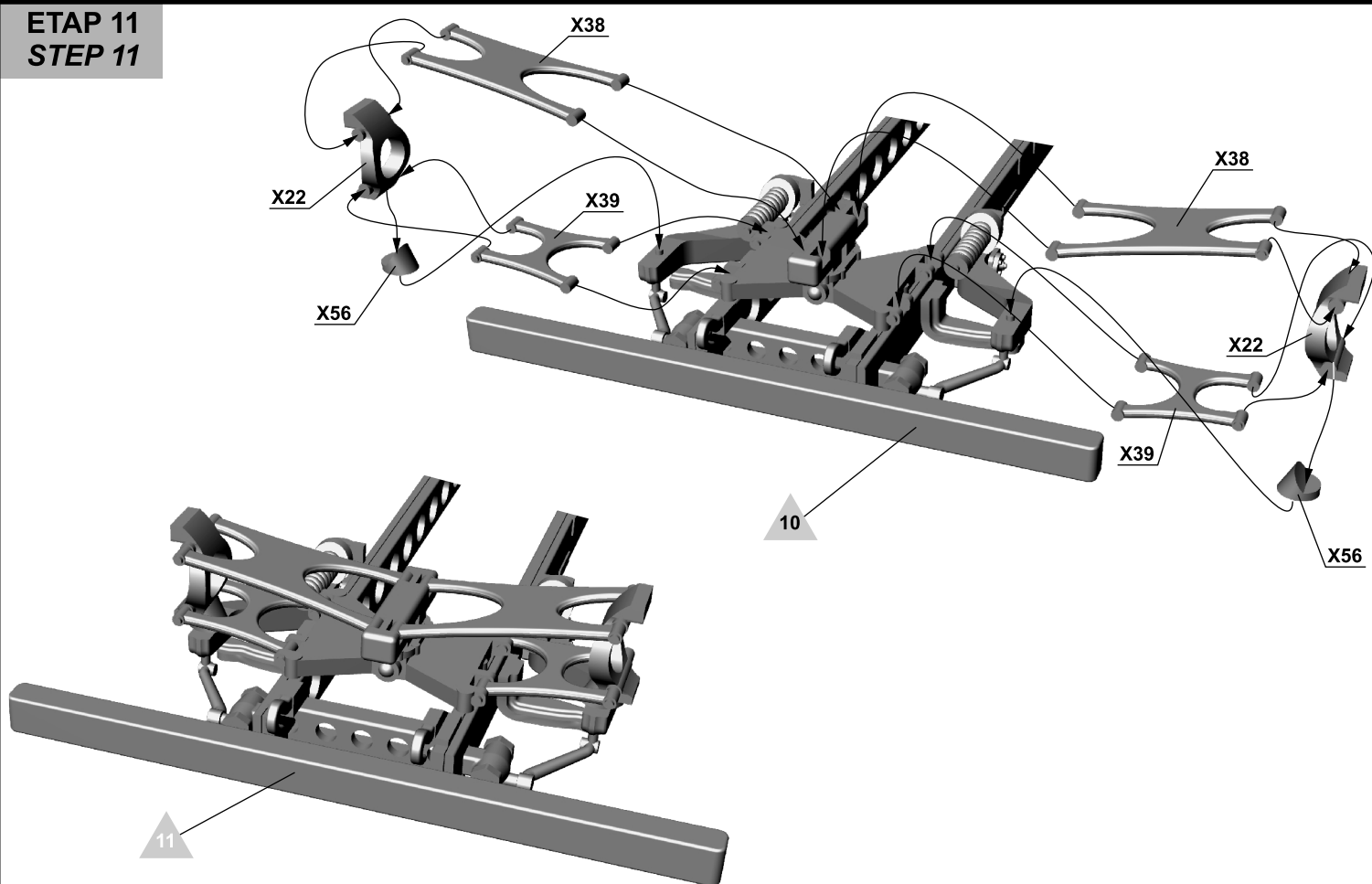

ETAP 12
STEP 12

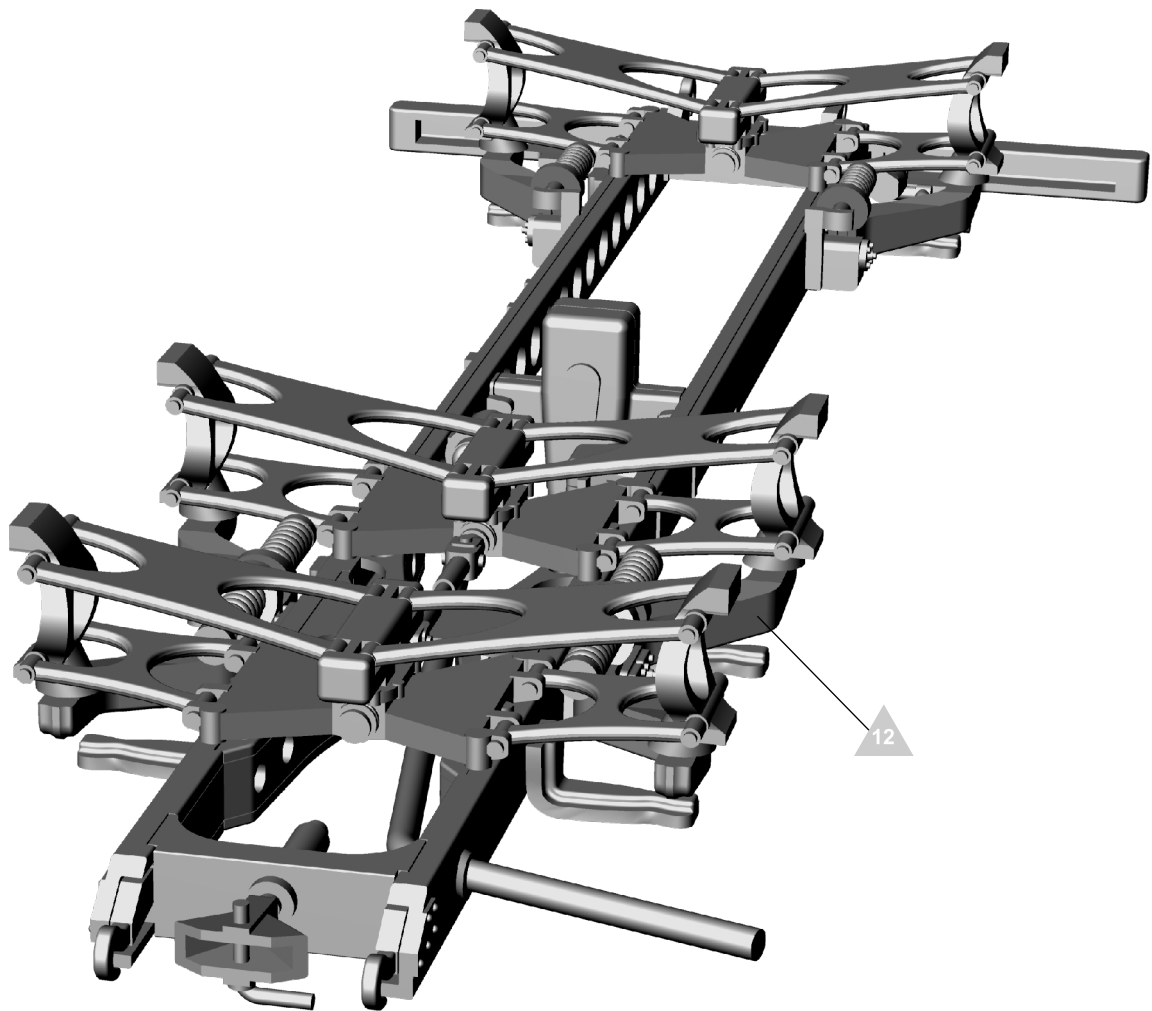
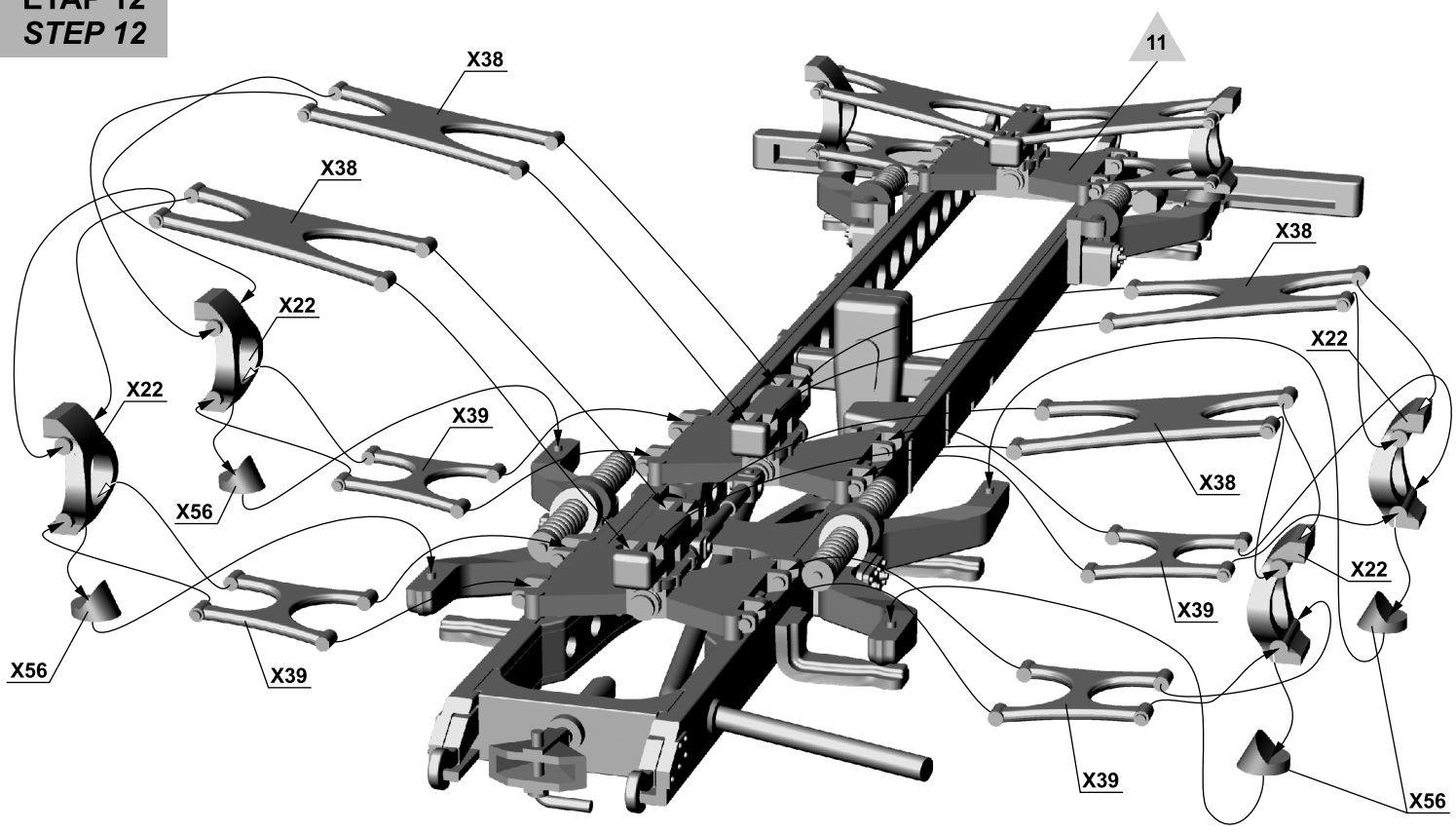

ETAP 13
STEP 13

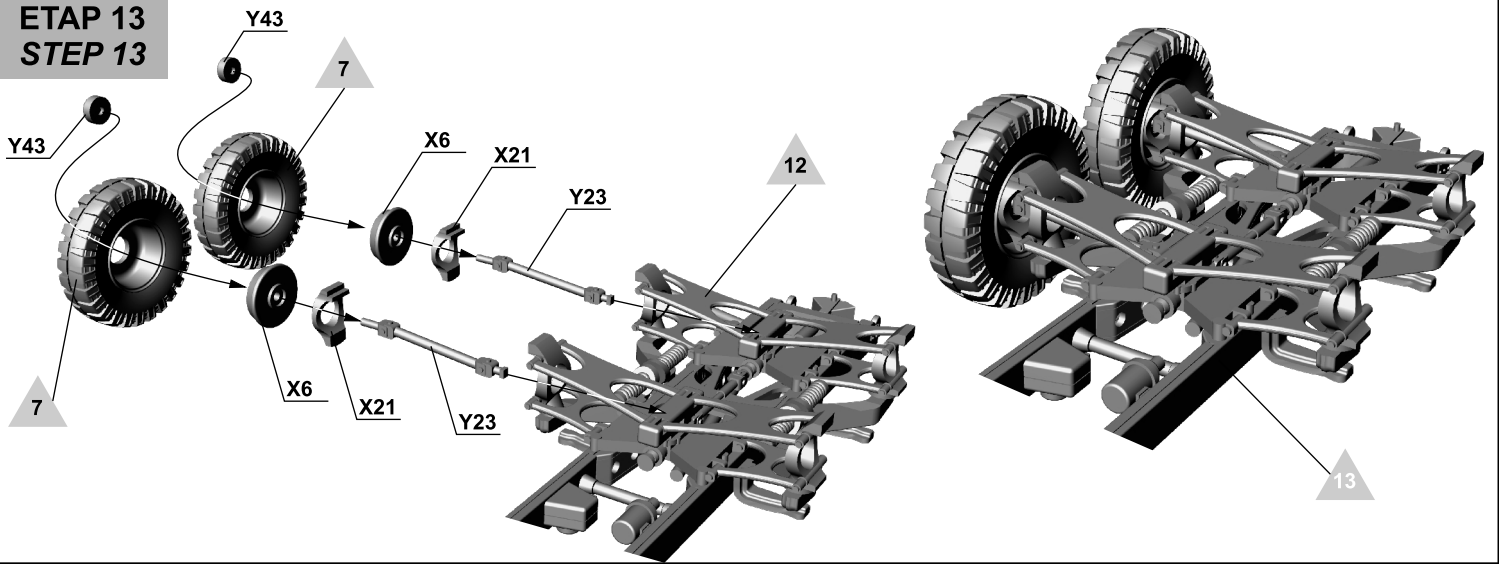

ETAP 14
STEP 14

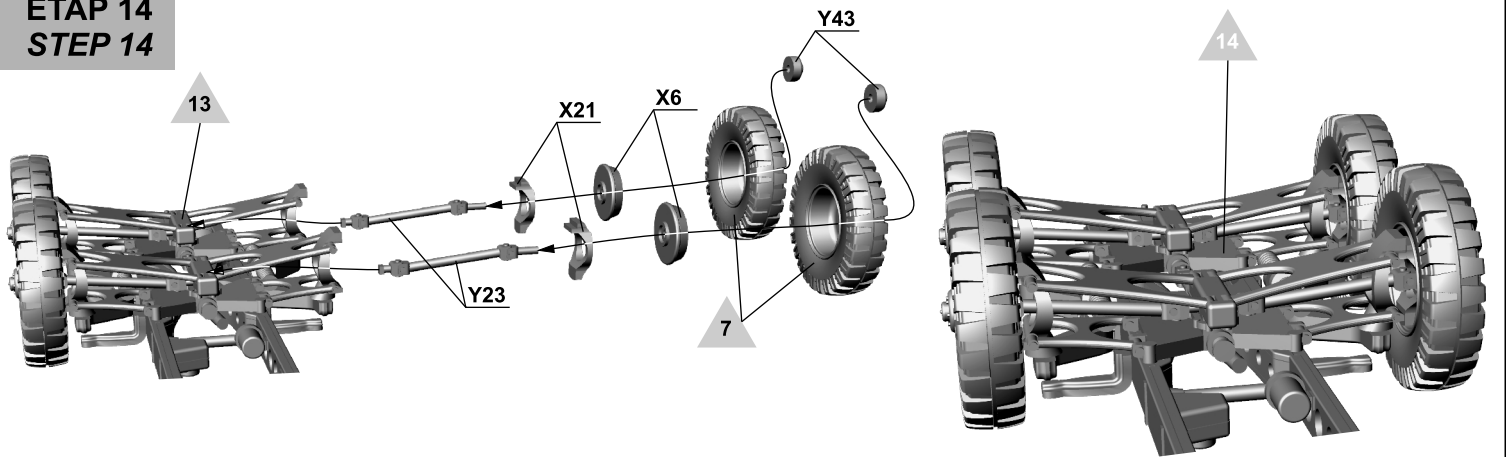

ETAP 15
STEP 15

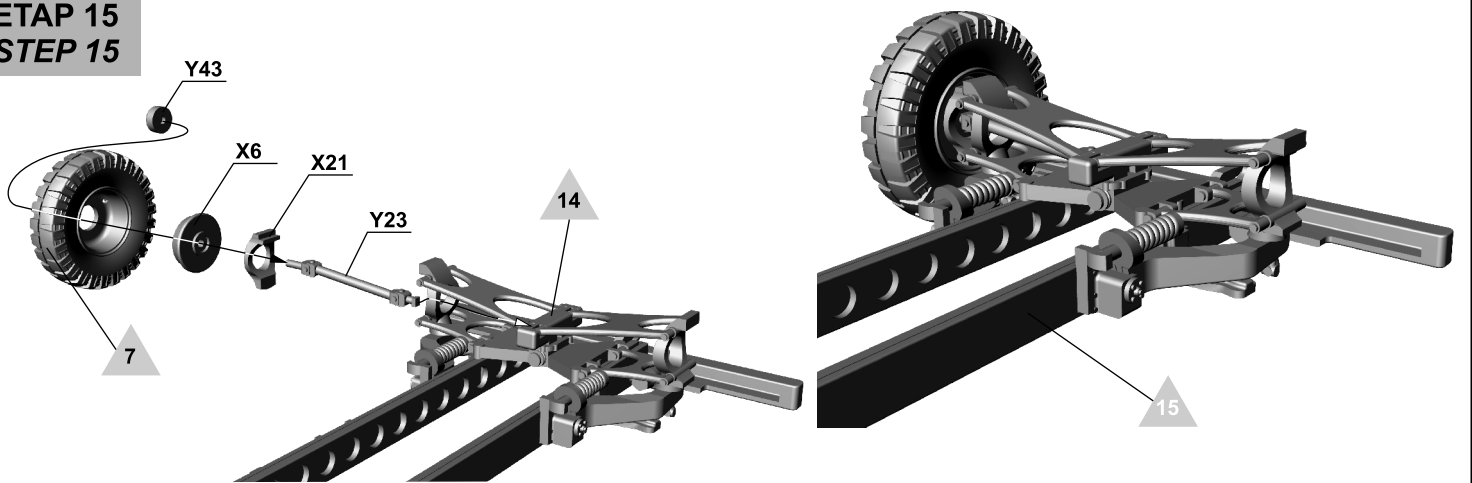

ETAP 16
STEP 16

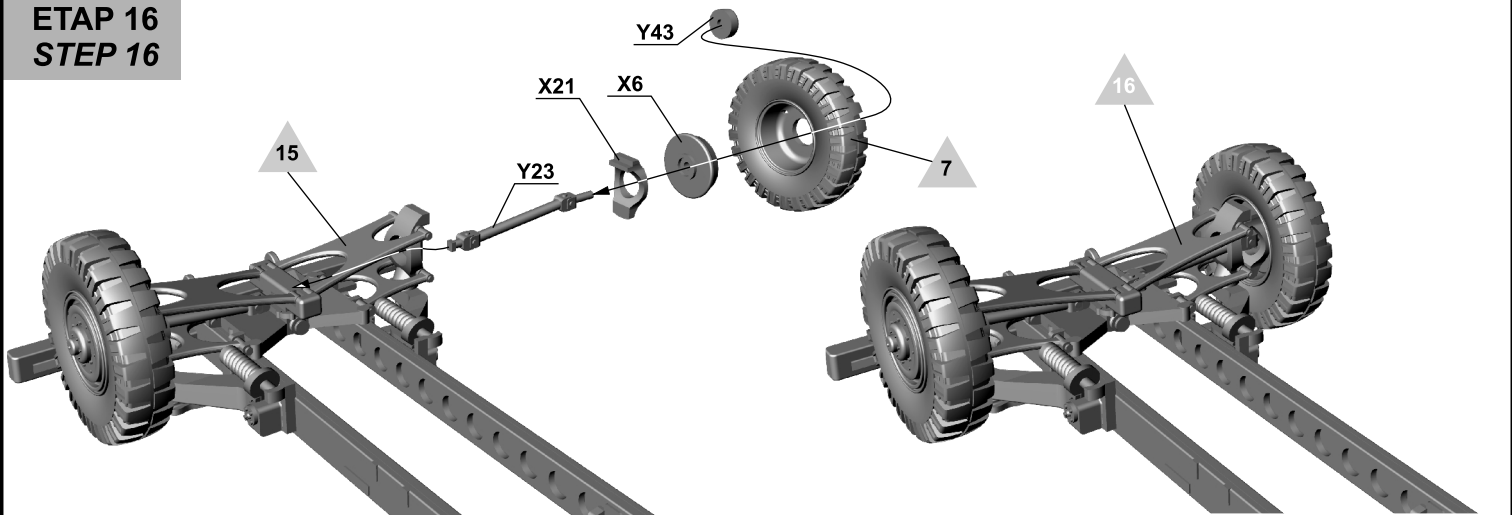

ETAP 17
STEP 17

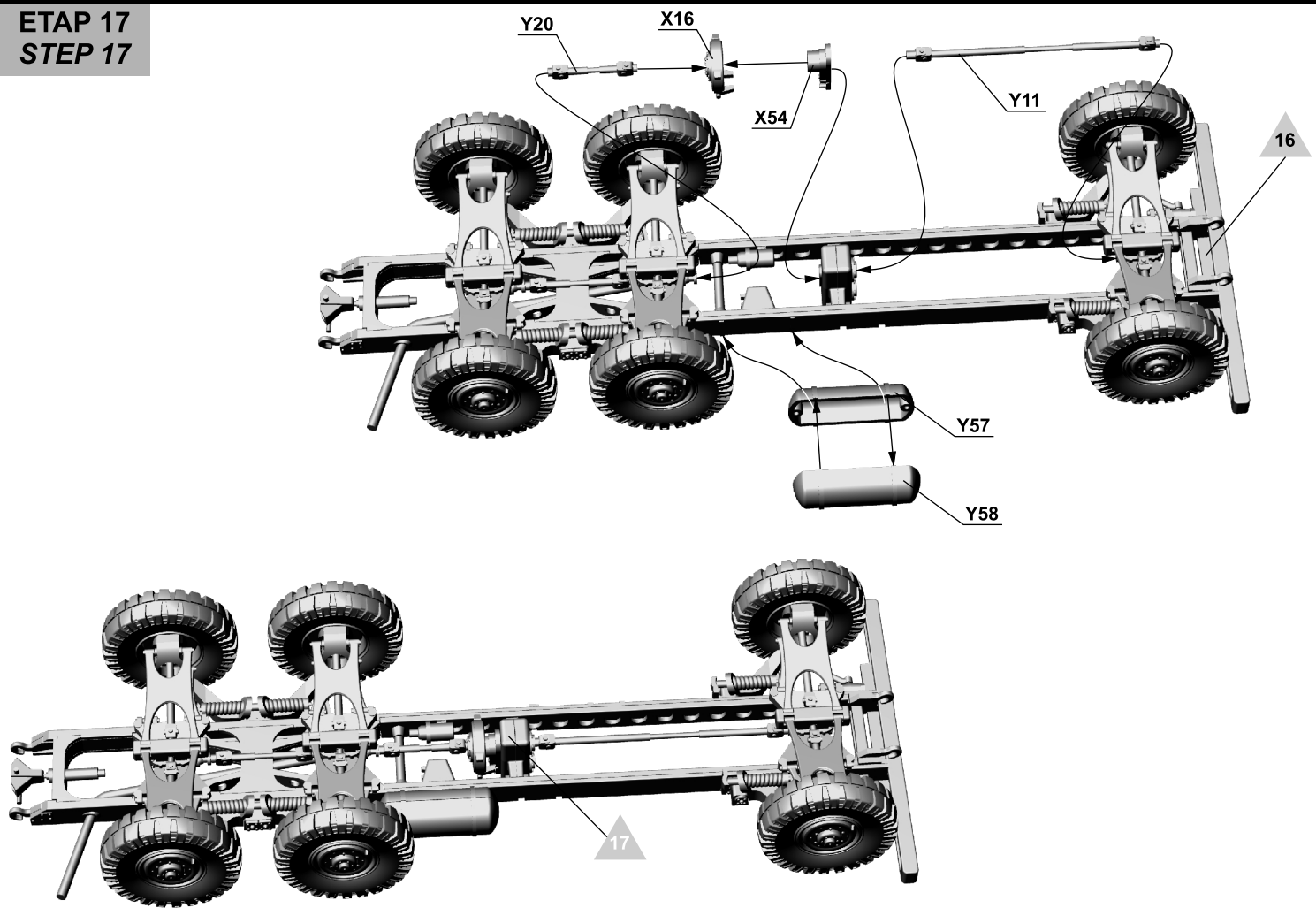

ETAP 18
STEP 18

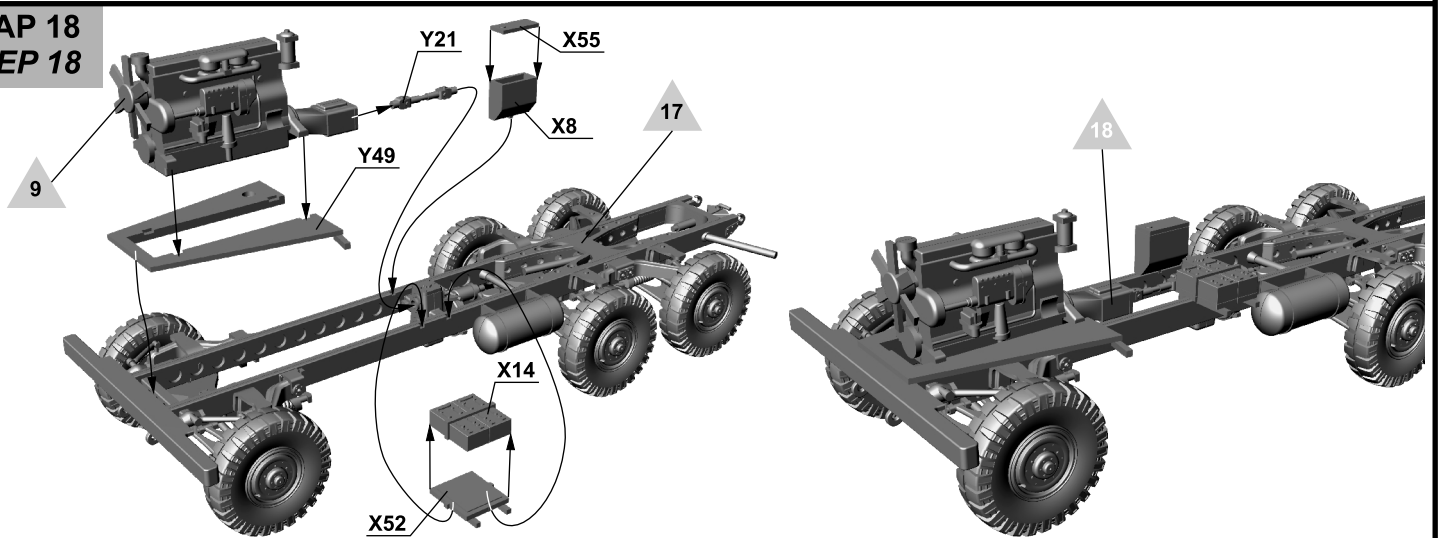

ETAP 19
STEP 19

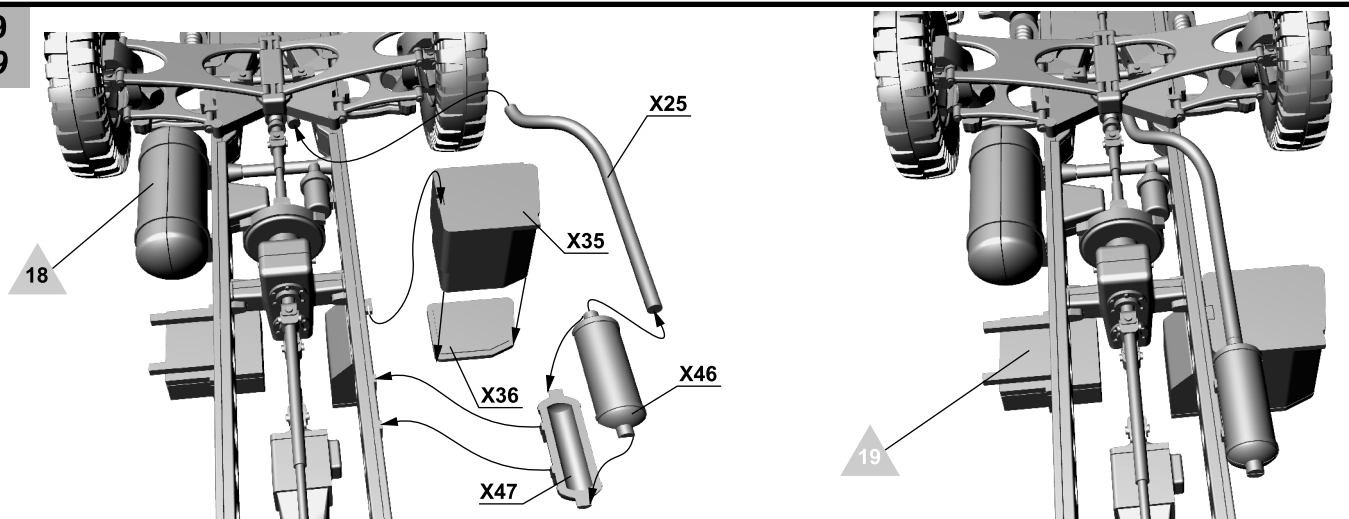

ETAP 20
STEP 20

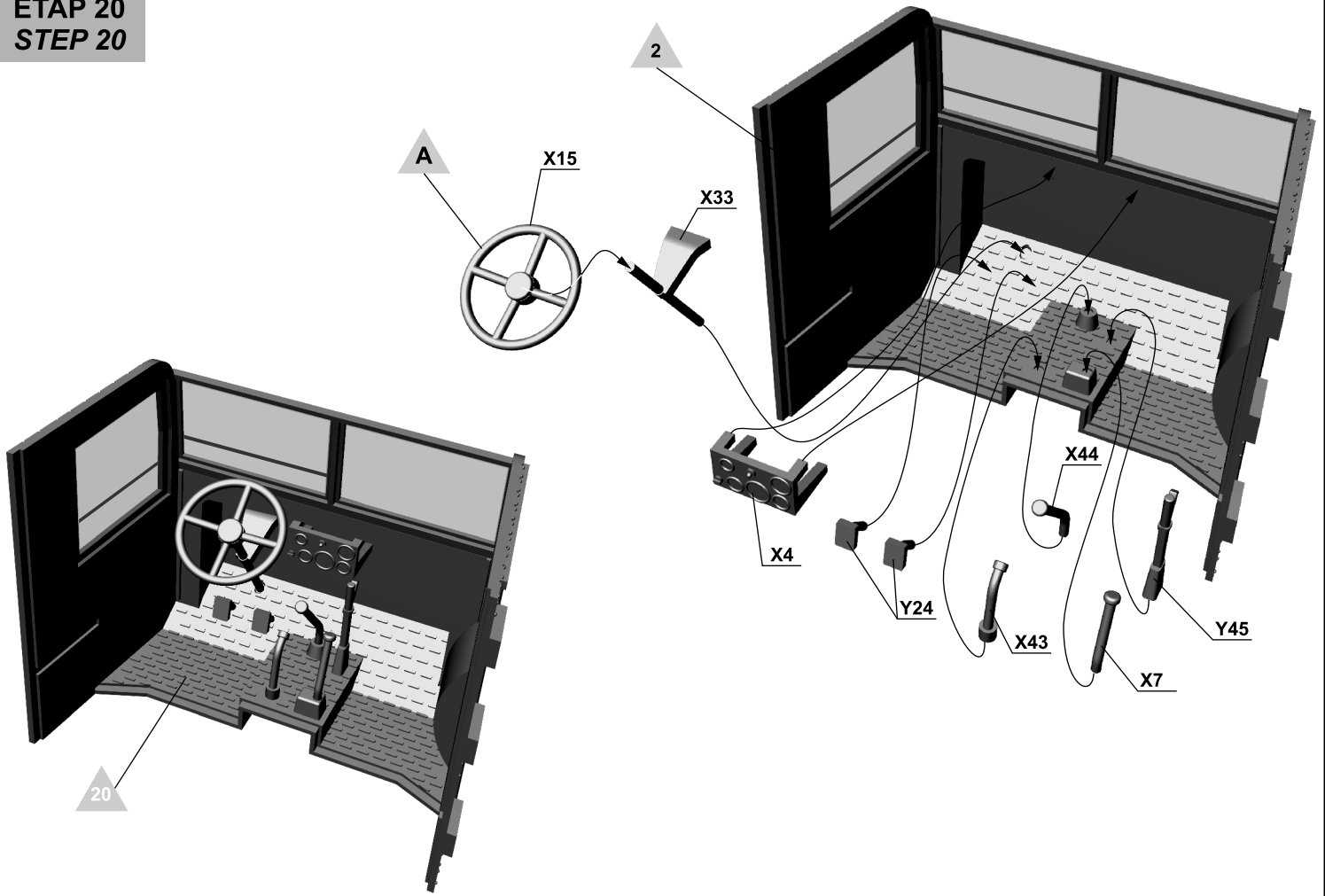

ETAP 21
STEP 21

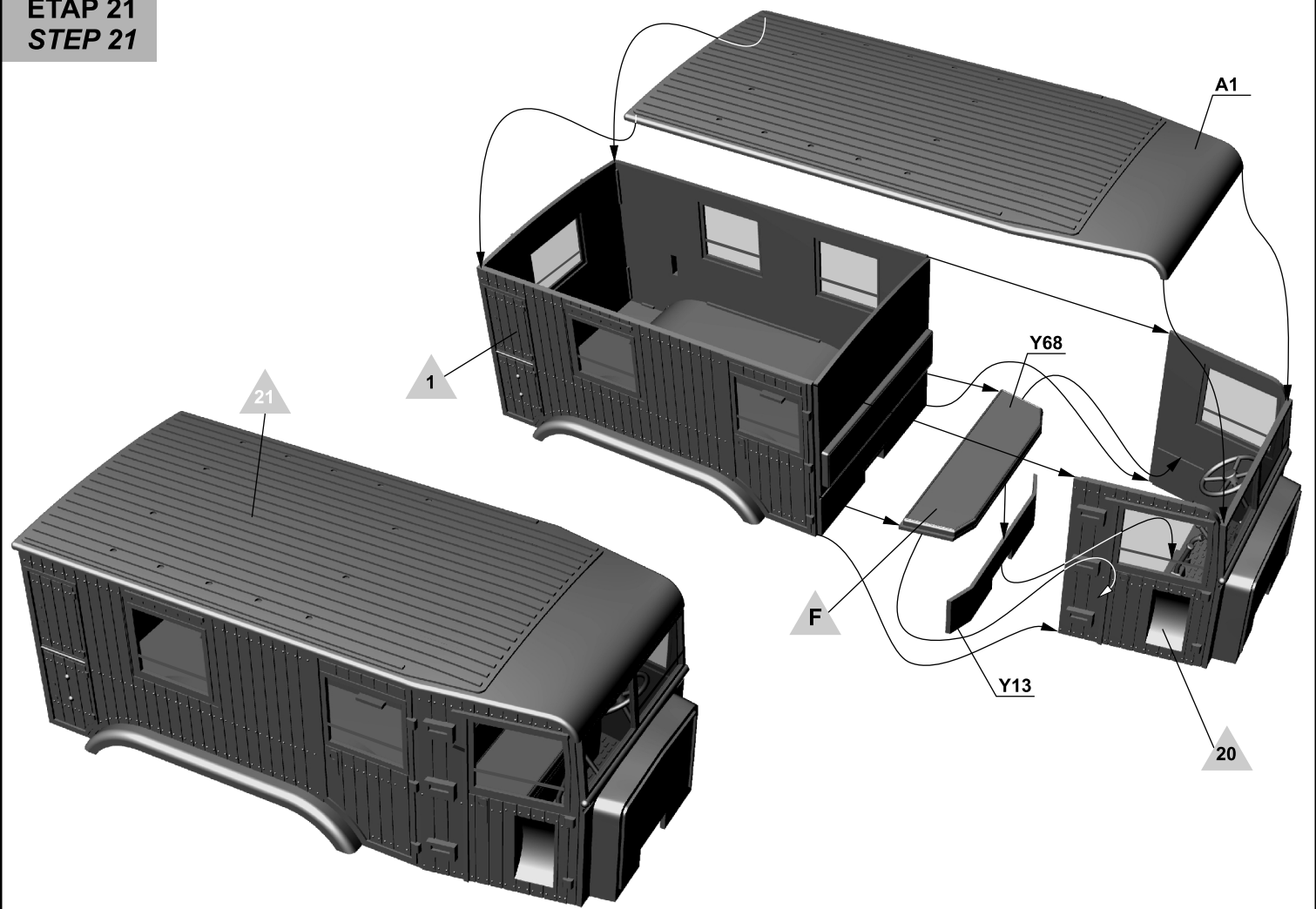

ETAP 22
STEP 22

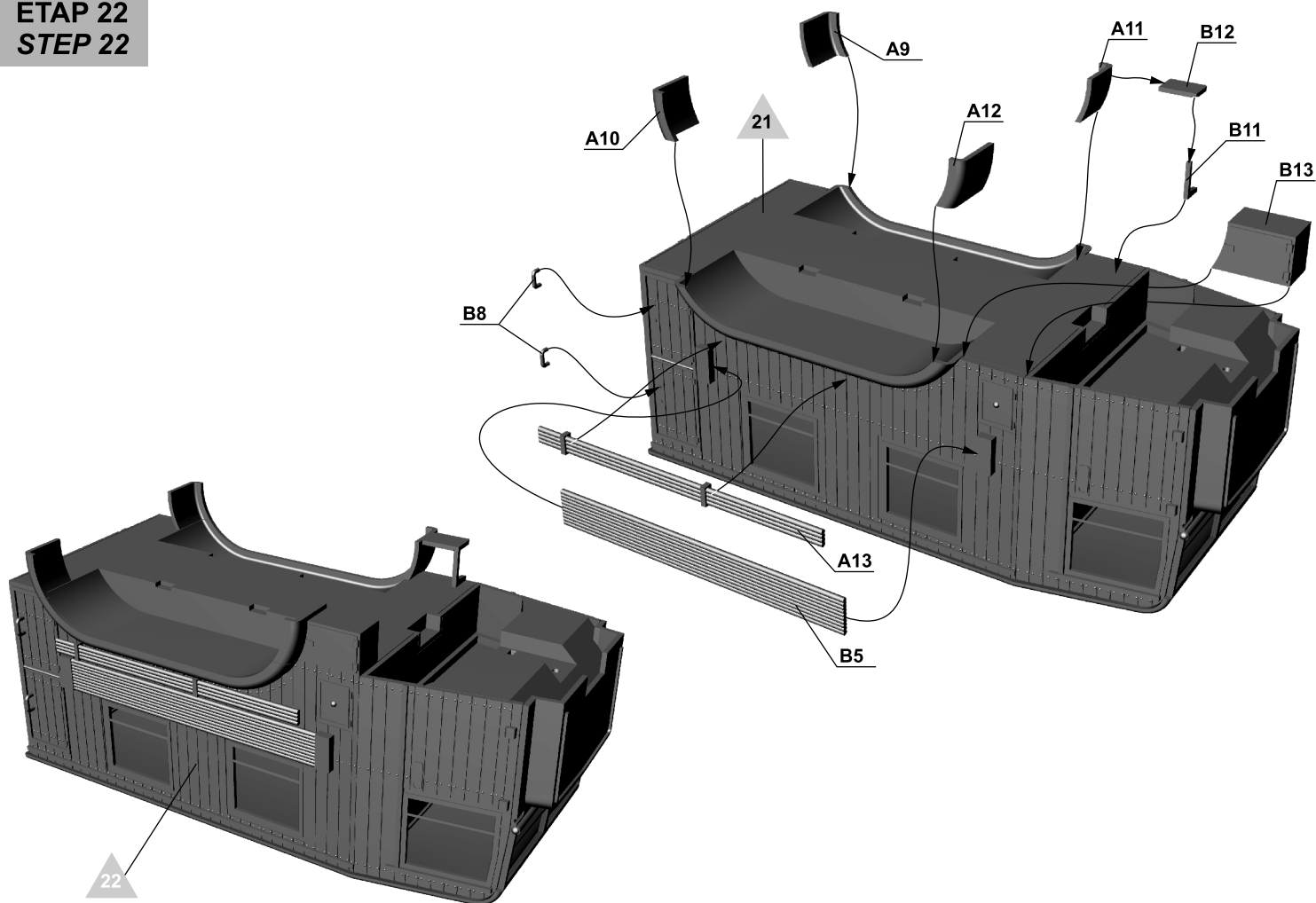

ETAP 23
STEP 23

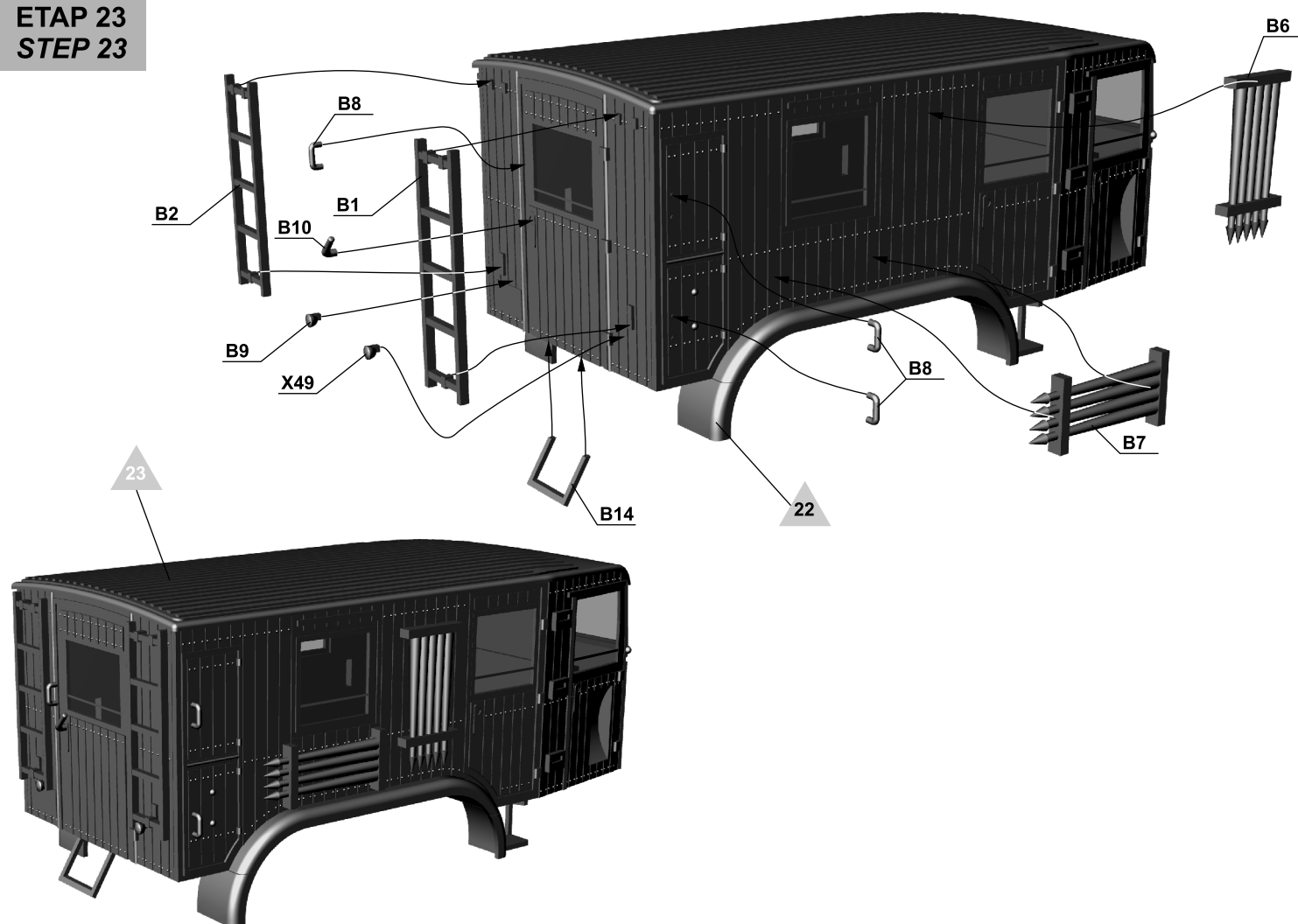

ETAP 24
STEP 24

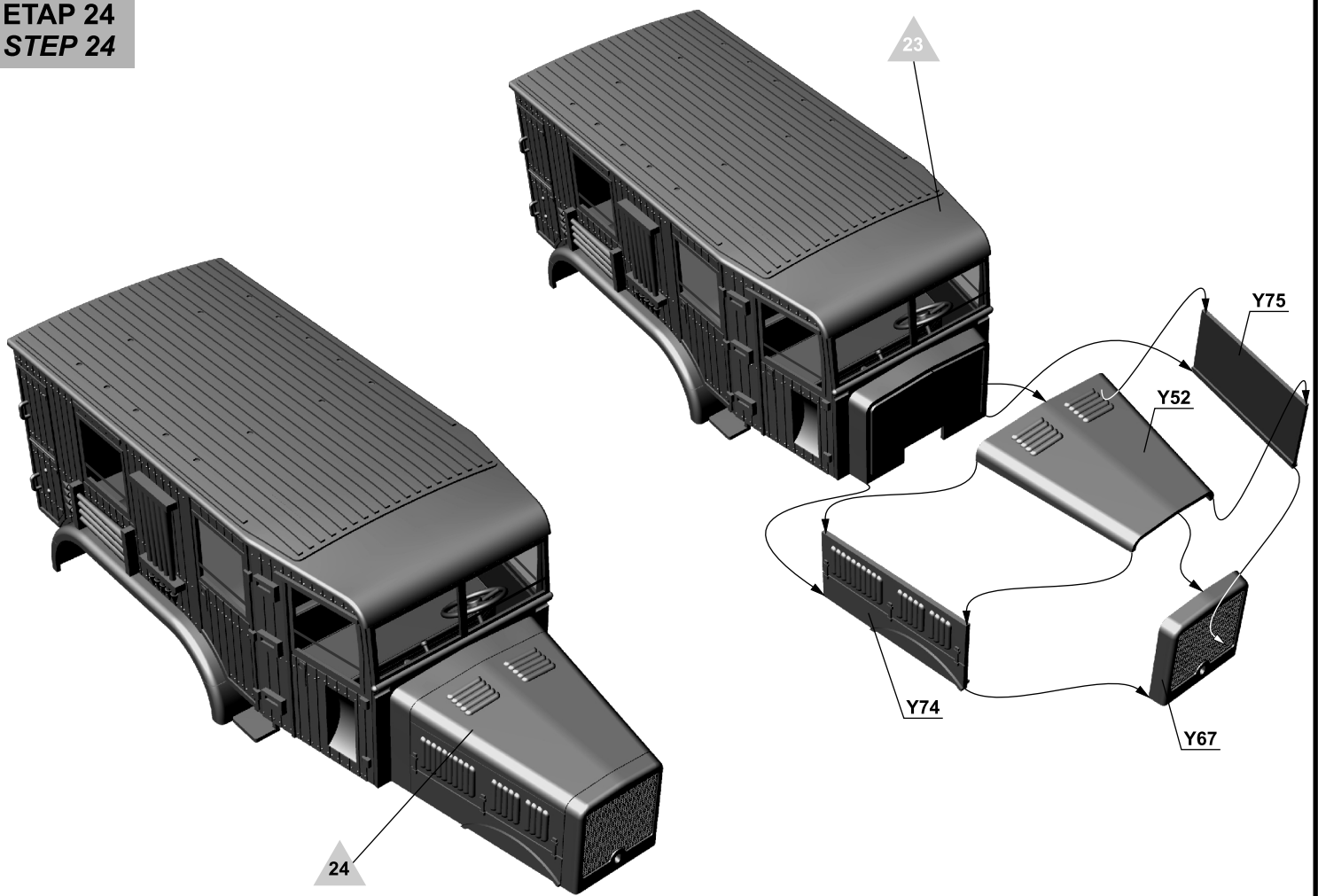

ETAP 25
STEP 25

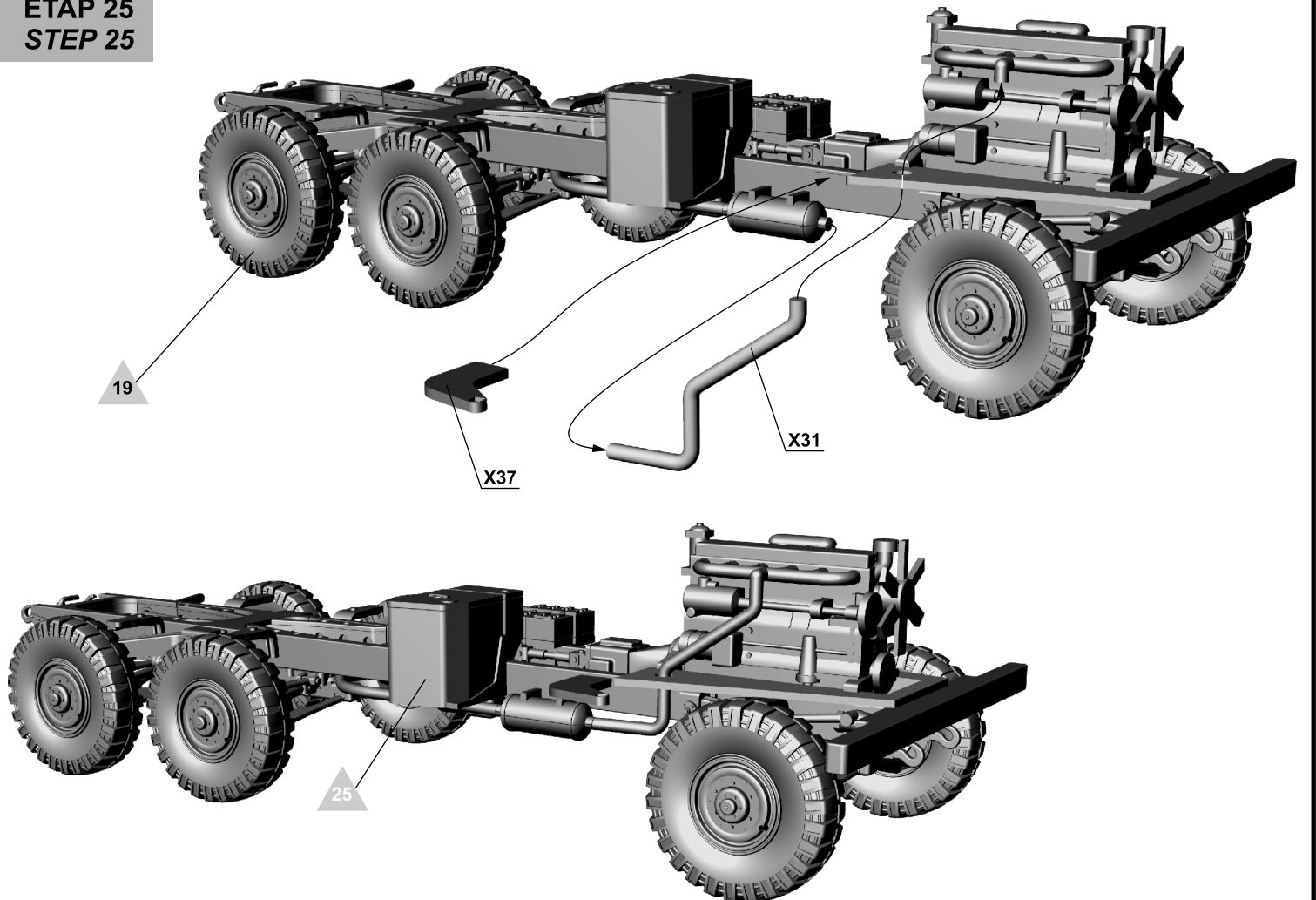

ETAP 26
STEP 26

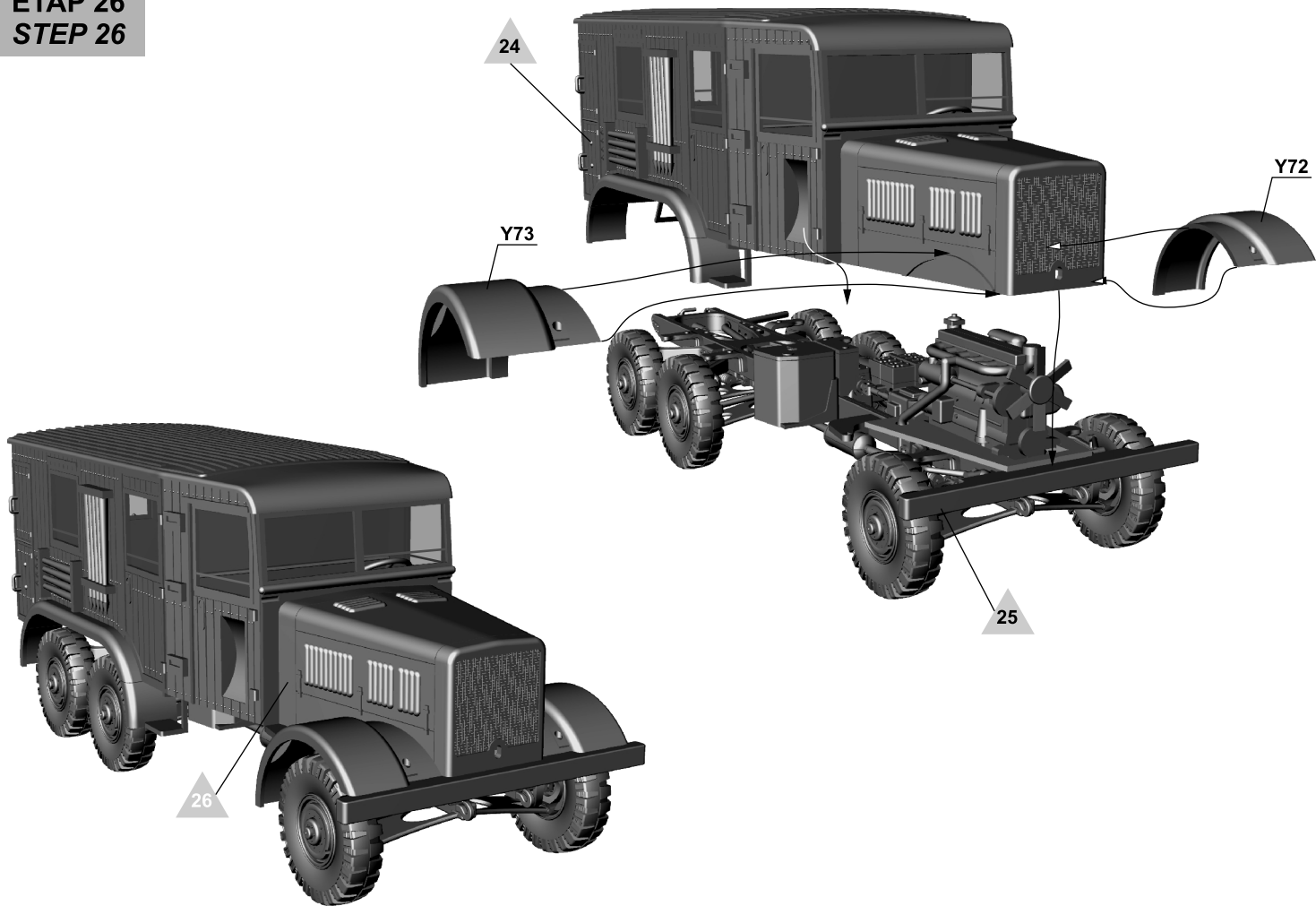

ETAP 27
STEP 27

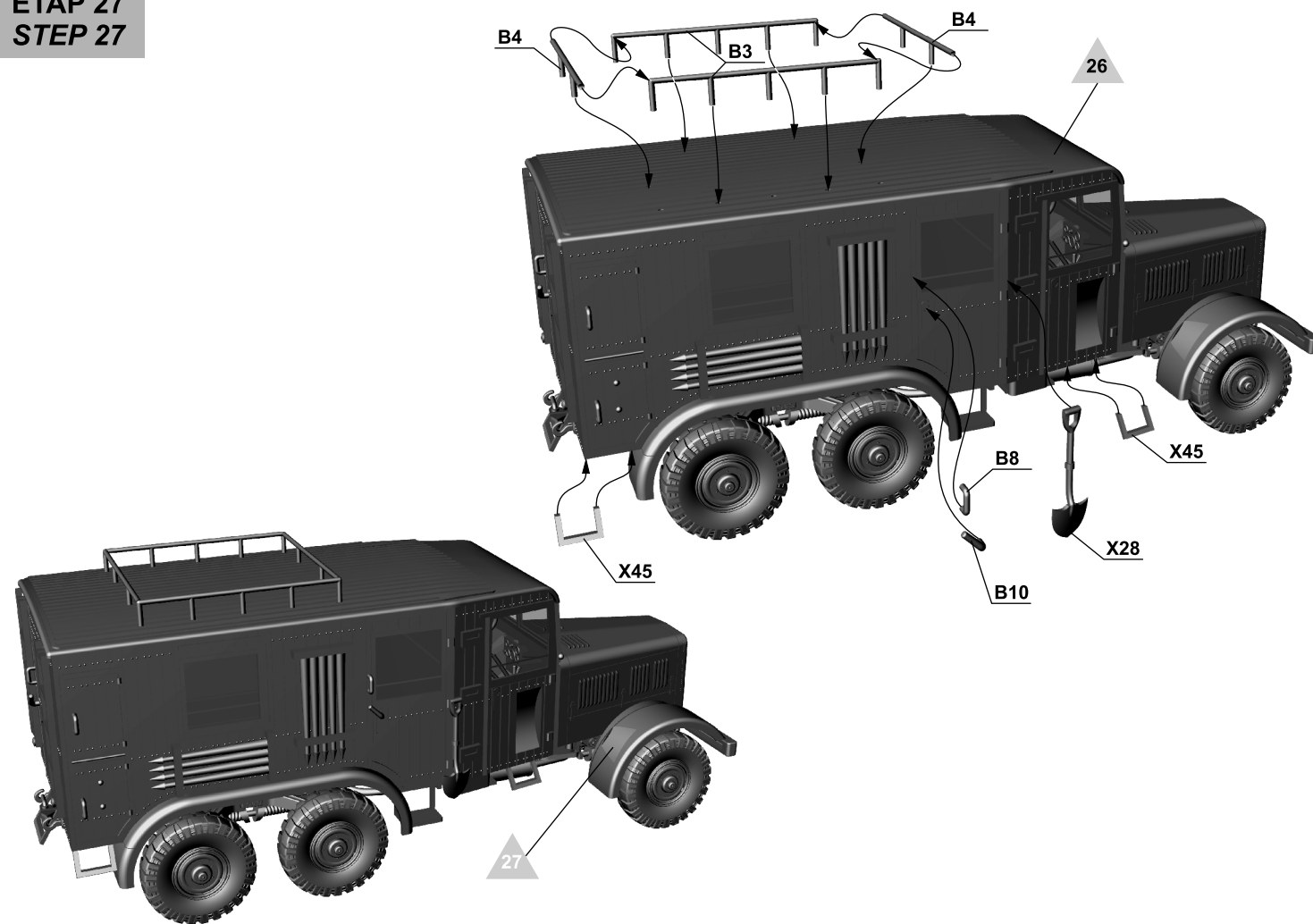

ETAP 28
STEP 28

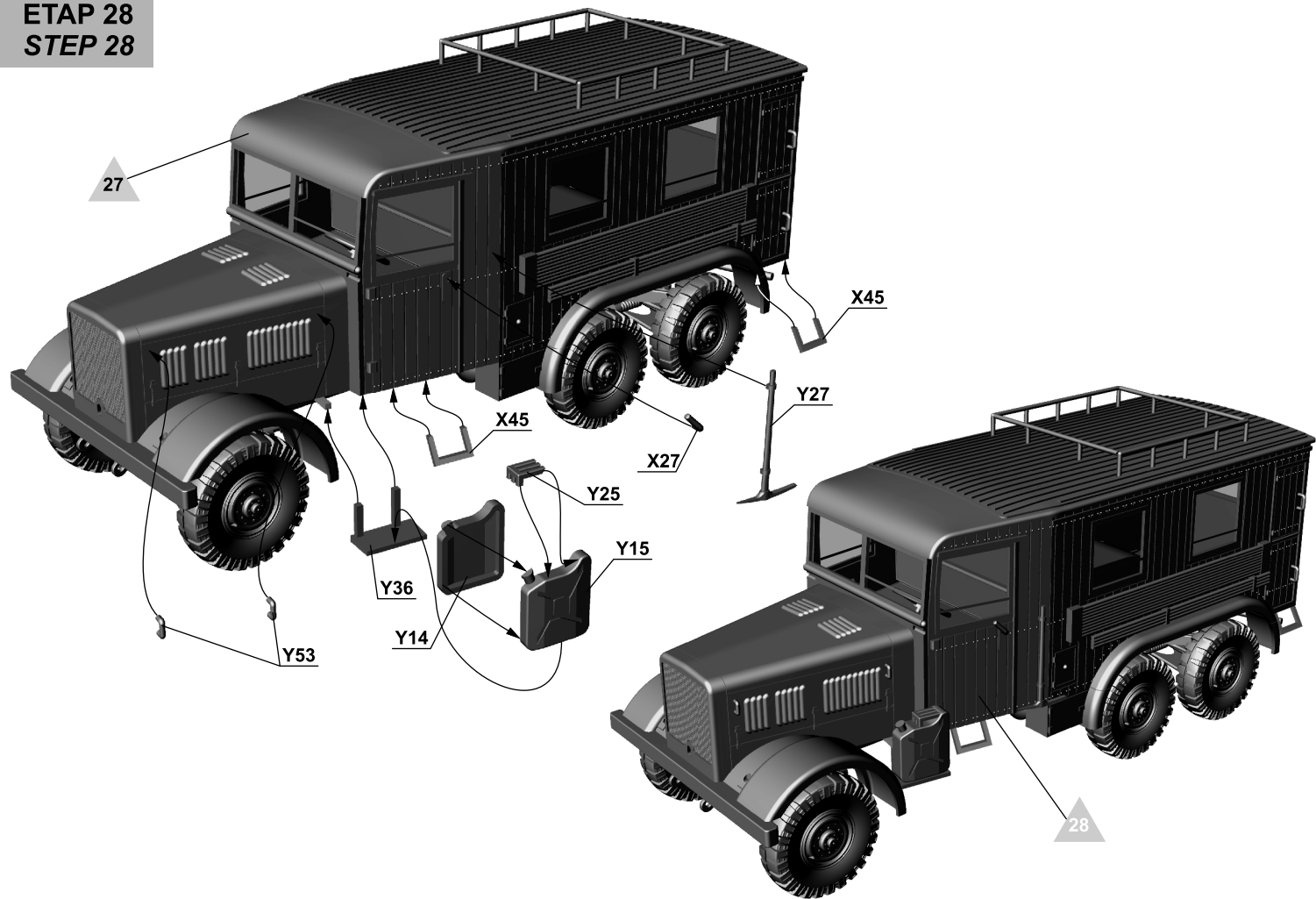

ETAP 29
STEP 29

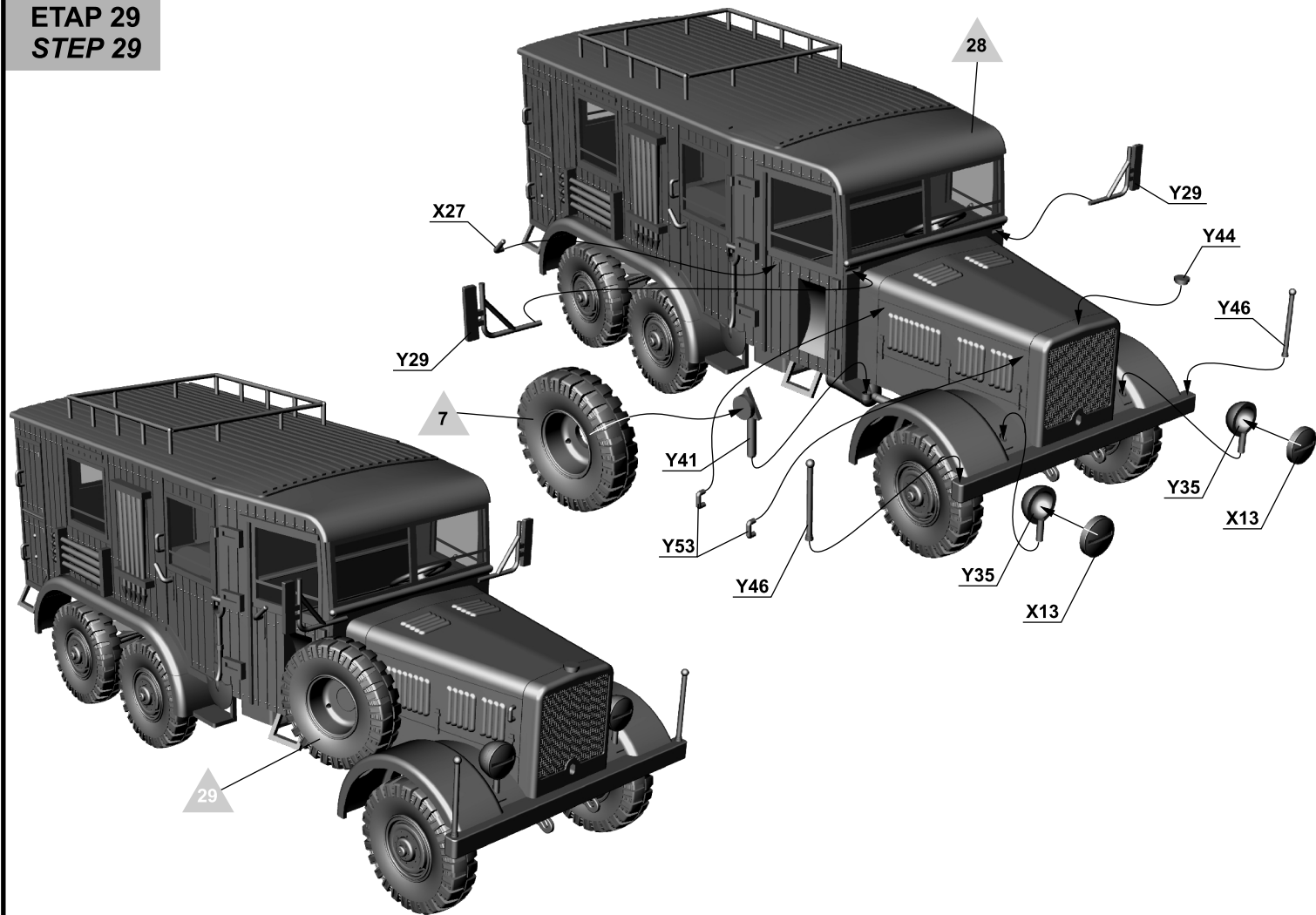

WYKONANY MODEL
FINISHED MODEL

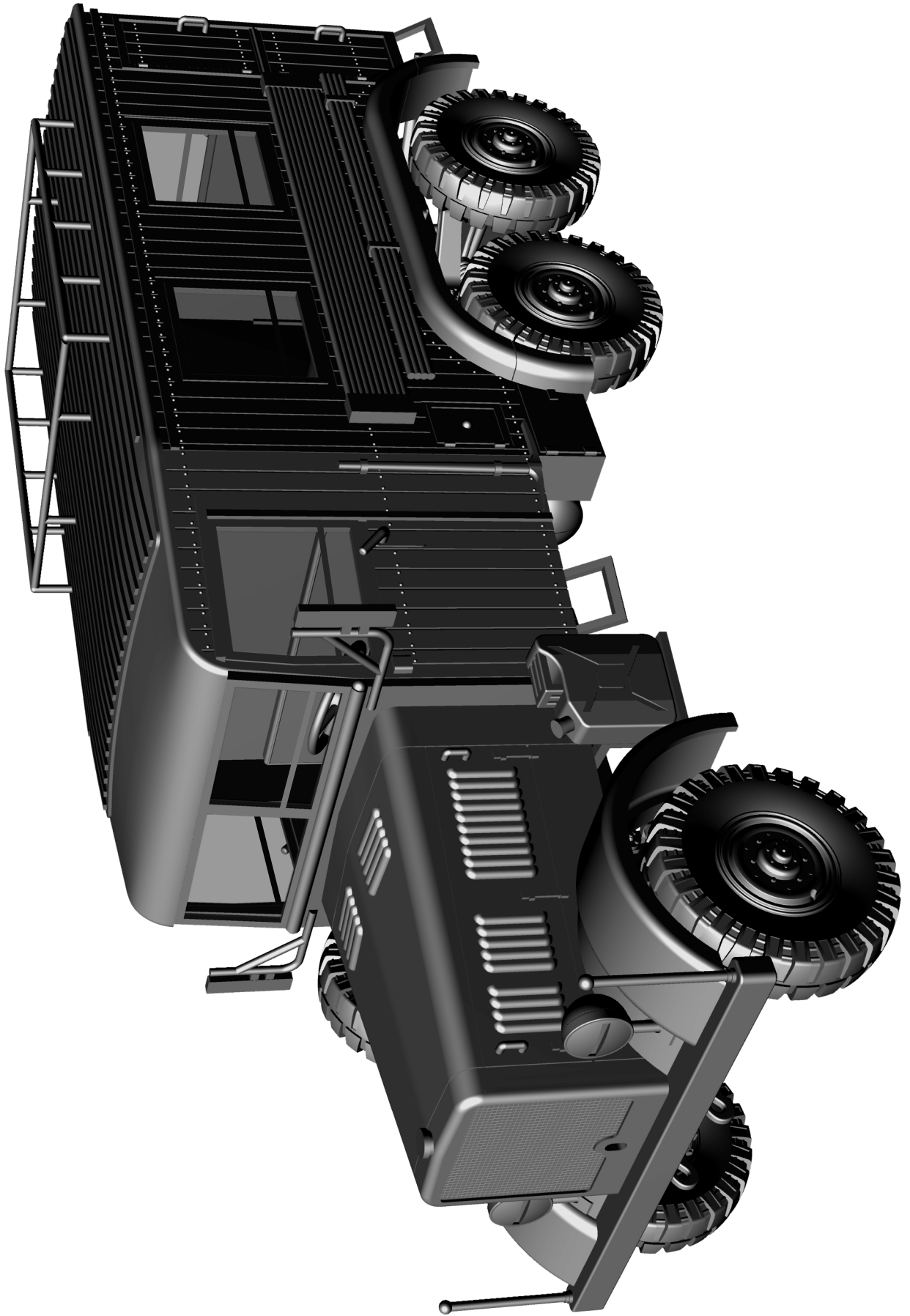

MALOWANIE I KALKOMANIE
COLOURS AND DECALS

Einheitsdiesel Kfz. 61 z 12go Batalionu Łączności
12tej Dywizji Piechoty
Francja, 1940
*Einheitsdiesel Kfz. 61 from 12th Signals Battalion of
12th Infantry Division (Einheitsdiesel Kfz. 61 der
Nachrichten-Abteilung 12 der 12.Infanterie-Division)
France, 1940*

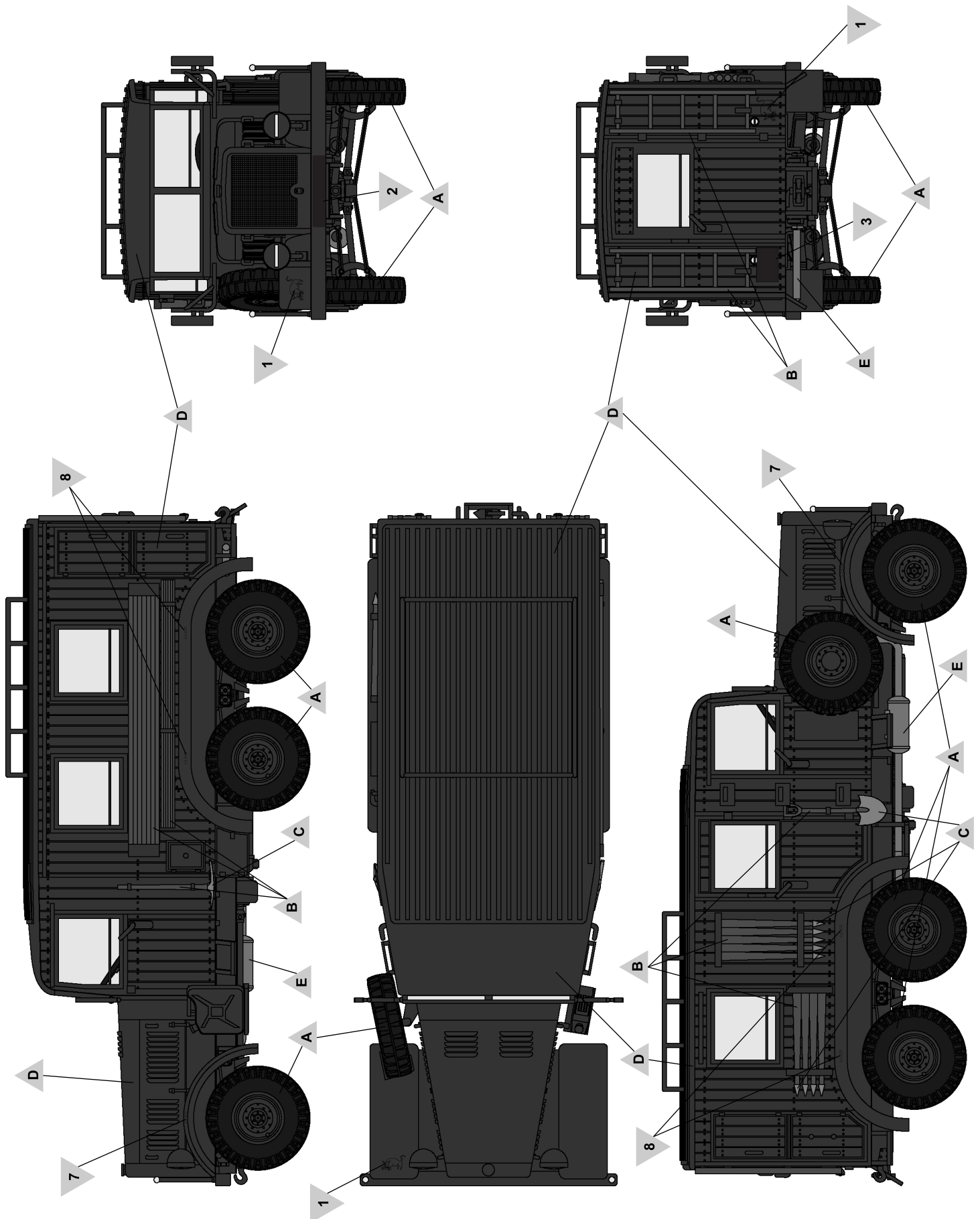

MALOWANIE I KALKOMANIE
COLOURS AND DECALS

Einheitsdiesel Kfz. 61 z 1go Batalionu Łączności
1szej Dywizji Piechoty
Rosja, czerwiec 1941
*Einheitsdiesel Kfz. 61 from 1st Signals Battalion of
1st Infantry Division (Einheitsdiesel Kfz. 61 der
Nachrichten-Abteilung 1 der 1. Infanterie-Division)
Russia, June 1941*

